



# Instruction Manual

Alfa Laval GJ 10



Covering:  
Standard Machines  
First published: 2015-07

100017030-EN2      2024-11

Original manual



*The information herein is correct at the time of issue but may be subject to change without prior notice.*

1. Declarations of Conformity .....	4
1.1. EU Declaration of Conformity .....	4.1
1.2. UK Declaration of Conformity.....	4.2
2. Safety .....	5
2.1. Important Information .....	5
2.2. Warning Signs .....	5
2.3. Safety Precautions .....	6
3. Introduction .....	7
3.1. Description .....	7
3.2. Intended Use .....	7
3.3. Trademarks.....	7
3.4. Marking .....	7
4. Installation .....	8
4.1. Unpacking/Delivery .....	8
4.2. Installation .....	9
4.3. Recycling Information .....	11
5. Operation .....	12
5.1. Operation/Control .....	12
5.2. Trouble Shooting .....	13
5.3. Cleaning Solution Leakage .....	14
5.4. Poor Cleaning Performance .....	15
5.5. Recommended Cleaning .....	16
6. Maintenance .....	17
6.1. General Maintenance .....	17
6.2. General Dismantling Setup .....	18
6.3. General Dismantling .....	19
6.4. Inspection and Service of Components .....	20
6.5. Reassembly .....	23
7. Technical Data .....	25
7.1. Technical Data .....	25
7.2. Performance Data .....	26
7.3. Dimensions .....	27
7.4. Trax Simulation Tool .....	28
8. Parts List and Service Kits .....	29
8.1. AL GJ 10 View .....	29
8.2. Assembly Drawings – 1, 2, 3 & 4 .....	30
8.3. Assembly Drawings – 5, 6, 7, 8, 9 & 10 .....	31
8.4. Assembly Drawings – 11, 12, 13, 14 & 15 .....	33
8.5. Assembly Drawing – 16 .....	35
8.6. Assembly Drawings – 17, 18, 19 & 20 .....	36
8.7. Assembly Drawing – 21 .....	37
8.8. Assembly Drawing – 22 .....	38
8.9. Parts List .....	39
8.10. Minor Service Kit .....	41
8.11. Major Service Kit .....	42

# 1. Declarations of Conformity

---

## 1.1 EU Declaration of Conformity

---

The designated company

Alfa Laval Kolding A/S, Albuen 31, DK-6000 Kolding, Denmark, phone no. +45 79 32 22 00

Company name, address and phone number

hereby declare that

Rotary Jet Head

Designation

GJ 10

Type

Serial numbers from X-100 to X-xxxx

is in conformity with the following directives with amendments:

- Machinery Directive 2006/42/EC

The person authorised to compile the technical file is the signer of this document.

Vice President BU Hygienic Fluid Handling  
Head of Product Management

Title

Mikkel Nordkvist

Name

Kolding, Denmark

Place

2024-11-12

Date (YYYY-MM-DD)



Signature

This Declaration of Conformity replaces Declaration of Conformity dated 2015-05-18  
DoC Revision\_01\_112024



# 1. Declarations of Conformity

---

## 1.2 UK Declaration of Conformity

---

The designated company

Alfa Laval Kolding A/S, Albuen 31, DK-6000 Kolding, Denmark, phone no. +45 79 32 22 00

Company name, address and phone number

hereby declare that

Rotary Jet Head

Designation

GJ 10

Type

Serial numbers from X-100 to X-xxxx

is in conformity with the following directives with amendments:

- Supply of Machinery (Safety) Regulations 2008

Signed on behalf of: Alfa Laval Kolding A/S

Vice President BU Hygienic Fluid Handling  
Head of Product Management

Title

Mikkel Nordkvist

Name

Kolding, Denmark

Place

2024-11-12

Date (YYYY-MM-DD)



Signature

DoC Revision\_01\_112024



---

*Unsafe practices and other important information are emphasized in this manual.  
Warnings are emphasized by means of special signs.  
**Always read the manual before using the tank cleaning machine!***

---

## 2.1 Important Information

---

**WARNING**

Indicates that special procedures must be followed to avoid serious personal injury.

**CAUTION**

Indicates that special procedures must be followed to avoid damage to the tank cleaning machine.

**NOTE**

Indicates important information to simplify or clarify procedures.

---

## 2.2 Warning Signs

---

**General warning:**



**Dangerous electrical voltage:**



**Caustic agents:**



## 2 Safety

---

*All warnings in the manual are summarized on this page.*

*Pay special attention to the instructions below so that severe personal injury and/or damage to the tank cleaning machine are avoided.*

---

### 2.3 Safety Precautions

---

#### Installation:

**Always** read the technical data thoroughly. (See chapter 7 Technical Data)

Any tank-cleaning machine can develop a static electricity charge while in operation.

If the tank being cleaned contains a combustible liquid or vapor having a risk of ignition or explosion, it is imperative to have the Alfa Laval Gamajet properly grounded using the provided location on the unit.



#### Operation:

**Always** read the technical data thoroughly. (See chapter 7 Technical Data)

Necessary precautions must be taken if leakage occurs as this can lead to hazardous situations.



Always handle lye and acid with great care.

When an Alfa Laval Gamajet is operating, there should be covers over every tank opening.



These covers should be sealed well enough to withstand the full force of the jet striking the cover plate.

If the cleaning solution were hot, corrosive, or toxic, a leak would present a serious hazard to any personnel

in the immediate vicinity or to any exposed electrical equipment.



Warning: Any tank-cleaning machine can develop a static electricity charge while in operation. If the tank being cleaned contains a combustible liquid or vapor having a risk of ignition or explosion, it is imperative to have the Alfa Laval Gamajet properly grounded using the provided location on the unit.



#### Maintenance:

**Always** read the technical data thoroughly. (See chapter 7 Technical Data).

**Never** service the tank cleaning machine when it is hot.

**Always** use Alfa Laval genuine spare parts.



#### Transportation of the tank cleaning machine:

**Always** drain the tank cleaning machine head and accessories of any liquid

**Always** use original packaging or similar during transportation

---

---

### 3.1 Description

---

The Alfa Laval GJ 10 is a fluid-driven (turbine-driven) 360° rotary nozzle machine designed for cleaning the interior surfaces of a wide variety of process vessels with a minimum opening of 101.6mm (4.00 inches) in diameter. It is powered entirely by the cleaning solution and it requires no electricity, compressed air or lubricant for operation. The Alfa Laval GJ 10 is designed for both portable and CIP (Clean in Place) applications. If the Alfa Laval GJ 10 is permanently mounted inside a tank, we strongly recommend inspecting the unit every few hundred hours of operation.

**Warning: Under no conditions, whatsoever, should the Alfa Laval GJ 10 ever be immersed in anything, unless you have prior approval from Alfa Laval Gamajet Equipment. Failure to comply with this restriction will void the warranty!!**

In order to handle the broadest possible range of applications, the stainless steel Alfa Laval GJ 10 is available with an extensive selection of nozzle sizes, stators (non-rotating turbine), and O-ring materials. The nozzles are available as 6.4mm, 7.9mm, and 9.5mm (1/4", 5/16", and 3/8"). The Alfa Laval Gamajet wash cycle time can be adjusted for special applications by changing the stator and/or nozzle size. Interchangeable stators and nozzle sizes are available for either low or high pressures and/or flow rates. The performance capabilities of these options are detailed in Section 7 – Technical Data.

---

### 3.2 Intended Use

---

It is to be verified by the end-user:

- That the tank cleaning machine is in conformity with respect to tank, vessel or container size in which it will be used.
- That the construction materials (both metallic and non-metallic) are compatible with product, flushing media, cleaning media, temperatures and pressure under the intended use.

---

### 3.3 Trademarks

---

This Instruction Manual is published by Alfa Laval Tank Equipment without any warranty. Improvements and changes to this Instruction Manual may at any time be made by Alfa Laval Tank Equipment without prior notice. Such changes will, however, be incorporated in new editions of this Instruction Manual.

© Alfa Laval Tank Equipment, All rights reserved.

The Alfa Laval logotype is a trademark or the registered trademark of Alfa Laval Corporate AB. "Gamajet" is a trademark or registered trademark of Alfa Laval Tank Equipment. Other products or company names mentioned herein may be the trademarks of their respective owners. Any rights not expressly granted herein are reserved.

---

### 3.4 Marking

---

Alfa Laval Gamajet tank cleaning machines are all marked to allow recognition of machine type, machine name, Serial number and manufacturing address. The marking is placed on the body of the tank cleaning machine.

Alfa Laval Tank Equipment – Coatesville, PA

---



## 4 Installation

---

---

### 4.1 Unpacking/Delivery

---

#### Step 1

CAUTION  
Alfa Laval cannot be held responsible for incorrect unpacking.

Check the delivery for:

1. Complete Cleaning Machine
  2. Delivery note
- 

#### Step 2

Remove any packing materials

---

#### Step 3

Inspect the tank cleaning machine for visible transport damage

Inspection!

---

---

Read the instructions carefully and pay special attention to the warnings! Always check the tank cleaning machine before operation.

---

## 4.2 Installation

---

### Step 1



Always read the technical data thoroughly.  
(See chapter 7 Technical Data)

---

### Step 2

#### Assembly

Every Alfa Laval Gamajet is operationally tested before shipment and is ready to run after unpacking. **No assembly is required prior to use.** The Alfa Laval Gamajet has been configured to meet the operating conditions (at the Alfa Laval Gamajet, not at the pump) given to us, e.g. pressure, flow, temperature, cycle time, chemical adders, etc.

**Note:** Any change to the original operating conditions will affect the Alfa Laval Gamajet accordingly

**Warning:** Do not force Tee & Nozzle Housing, Pos. 4 & 5 to rotate. Doing so may damage the internal components.

---

### Step 3

#### Inlet Connections

The standard inlet connection for the Alfa Laval GJ 10 is a 1-1/2" NPT female or 1-1/2" BSP. Others inlets are available. It is recommended that when using the pipe thread the mating male thread should be wrapped with PTFE pipe joint tape prior to mounting. This will minimize any chance of leakage and will make subsequent removal much easier.

---

### Step 4

#### Mounting

Before mounting the Alfa Laval GJ 10, make sure the supply line has been adequately flushed. It can be mounted on a rigid 1-1/2" pipe using a pipe wrench. In most applications, the Alfa Laval GJ 10 will be mounted with the inlet connection pointing up; however, the Alfa Laval GJ 10 will function at any orientation. In the cleaning of underground storage tanks (USTs), Alfa Laval Gamajet recommends the use of its UST Lance or Hose Insertion Assembly. Either device will ensure a proper insertion depth, sealing of the riser pipe. Also, the UST Lance includes a lanyard loop that provides a means to attach a safety line between the Alfa Laval GJ 10 UST Lance and the safety loop on the Alfa Laval Gamajet.

We do not recommend attaching the machine to a hose while in the inverted or horizontal orientation. This form of mounting is not rigid and, thus, will not maintain the Alfa Laval GJ 10's position should the unit become unbalanced due to clogging of the nozzles.

**Warning:** When attaching the Alfa Laval GJ 10 onto the supply pipe, **ALWAYS** apply the wrench to the Inlet Collar (9) at the top/inlet of the unit. Never use a wrench on Stem (3), Tee Housing (4), or Tee Housing Cap (13) to tighten the unit onto the pipe. Doing so risks internally damaging the machine. Refer to Drawing 22 for an illustration.

---

### Step 5

#### Location inside Tank

Generally, a single Alfa Laval Gamajet machine will be positioned in the approximate center of the vessel in order to equalize the cleaning radius in all directions. Some vessels, however, may have specific cleaning problems such as coils or heavy deposits such as the liquid level line (bathtub ring). In these situations the Alfa Laval GJ 10 should be located closer to the difficult area for the best cleaning results.

Tanks with internal mechanisms or structures such as an agitator shaft, impellers or baffles will require careful positioning to minimize the "shadow" on areas which do not receive direct jet impact. Sometimes, more than one machine, or, more than one placement of a single machine, may be necessary to avoid shadow problems or "striping."

---

## 4 Installation

---

*Read the instructions carefully and pay special attention to the warnings! Always check the tank cleaning machine before operation.*

---

### Step 6

#### Entry Openings

When using the GJ 10, the vessels being cleaned must provide entry openings large enough to avoid interference during insertion and removal. The minimum opening size required for the GJ 10 is 4.00 inches in diameter (101.6 mm) for free-hand installation.

---

### Step 7

#### Vessel Drainage

If it is necessary to clean the floor of a vessel, remember that standing liquid will diminish the effectiveness of the jet by covering any soils underneath. Wherever possible, the tank floor should be pitched toward the drain and the drainage opening should be large enough to eliminate or reduce any liquid buildup or puddling. If gravity alone is insufficient, a scavenger or stripper pump should be connected to the drain to suck out the excess wash fluid. In extreme cases, it may be necessary to use smaller nozzles on the Alfa Laval GJ 10, or even to operate it intermittently to allow time for draining.

---

### Step 8

#### Filters and Strainers

All tank cleaning systems should be equipped with a filter or strainer that will trap solids **1/16" and larger (150 micron, 100 mesh)**, as these will not pass through the Alfa Laval GJ 10. These particles can become caught in one of the internal passages of the machine and cause it to stop turning or reduce its cleaning effectiveness due to a loss of flow. It will then be necessary to disassemble the Alfa Laval GJ 10 and remove the blockage.

In recirculated (closed-loop) cleaning, or, any other application where the cleaning solution may carry abrasive solids in suspension, adequate filtration is a must. These particles can be extremely destructive to the Alfa Laval Gamajet, pumps, valves, and other system components. Filters, properly installed and maintained, will more than pay for themselves with lower overall operating costs in these applications. Furthermore, to ensure that clogged filters or strainers are cleaned, we recommend using automatic self-cleaning models.

---

### Step 9

#### Capacity of Supply Pump

The Alfa Laval GJ 10 can be used with either a centrifugal or positive displacement (constant volume), PD, style pump. In most cases, if the unit is to be used with a centrifugal pump, the Alfa Laval Gamajet should be configured so that the pump will operate close to its best efficiency point. The end user must, therefore, take all of the plumbing, elevation, and Alfa Laval GJ 10 pressure/flow rate requirements into account.

If a PD style pump (i.e. piston pump, plunger pump, or mechanical diaphragm pump, etc.) will supply the wash fluid to the Alfa Laval GJ 10, a different set of rules apply. PD pumps are fixed volume pumps whose flow rate is dependent upon the rotational speed of the pump; the pumps also have a pressure rating which is the **maximum** operating pressure. **Note: Do not confuse the maximum operating pressure of a PD pump with the actual operating pressure, the actual operating pressure is dictated by the fixed flow rate of the pump and the Alfa Laval GJ 10 / plumbing system.** If a PD pump is used, the Alfa Laval GJ 10 should be sized to, first, match the flow capability of the pump and, second, not exceed the Alfa Laval GJ 10's or pump's maximum operating pressure (taking the pressure rating of the plumbing system into account, also).

**Warning: For high-pressure applications {over 10.3 bar (150 psig)}, the pressure of the system must "ramp up" to its operating pressure. If the system experiences a pressure spike or pressure increases at a rate of more than 10.3 bar (150 psi) per second, the machine may be damaged and parts will wear out prematurely. Damage resulting from this phenomenon is not covered by the warranty.**

---

*Read the instructions carefully and pay special attention to the warnings! Always check the tank cleaning machine before operation.*

---

### 4.3 Recycling Information

---

- **Unpacking**

- Packing material consists of wood, plastics, cardboard boxes and in some cases metal straps.
- Wood and cardboard boxes can be reused, recycled or used for energy recovery.
- Plastics should be recycled or burnt at a licensed waste incineration plant.
- Metal straps should be sent for material recycling.

- **Maintenance**

- All metal parts should be sent for material recycling.

- **Scrapping**

- At end of use, the equipment must be recycled according to relevant, local regulations. Beside the equipment itself, any hazardous residues from the process liquid must be considered and dealt with in a proper manner. When in doubt, or in the absence of local regulations, please contact your local Alfa Laval sales company.
-

## 5 Operation

---

*Read the instruction carefully and pay special attention to the warnings!*

---

### 5.1 Operation/Control

---

#### Step 1



Always read the technical data thoroughly. See chapter 7 Technical Data

#### CAUTION

Alfa Laval cannot be held responsible for incorrect operation/control.

---

#### Step 2



Never touch the tank cleaning machine or the pipelines when pumping hot liquids.

---

#### Step 3

##### Initial Startup

Every Alfa Laval GJ 10 that ships is accompanied by a Birth Certificate. This document indicates how the machine performed in our testing tank before it shipped based on the operating conditions supplied to Alfa Laval Gamajet. To ensure the longest possible life of the machine, please verify the operating conditions and, most importantly, the machine's cycle time. The cycle time can be measured by, first, picking a fixed point inside of a vessel as a reference and, second, timing how long it takes the same nozzle to pass back over that point in the vessel. (This, naturally, will not be the exact same spot because the spray pattern is indexing.) The measured time in seconds directly corresponds to the machines full cycle time in minutes. In other words, a single 10-second rotation translates to a 10 minute full cycle time.

---

Pay attention to possible faults  
Read the instructions carefully

## 5.2 Trouble Shooting

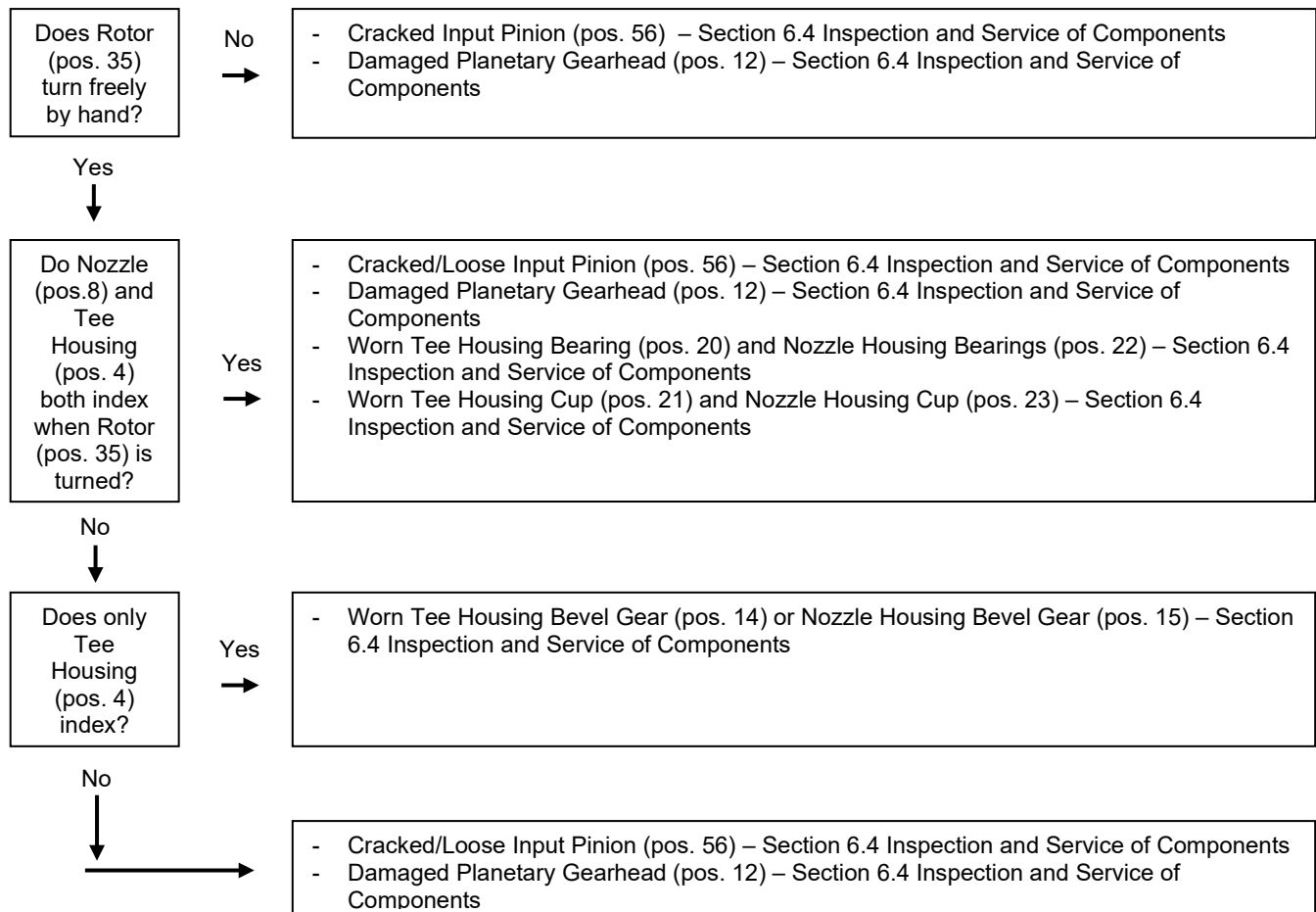

## 5 Operation

---

*Pay attention to possible faults  
Read the instructions carefully*

---

### Step 1

#### Insufficient Flow

The Alfa Laval GJ 10 was configured to meet certain operating conditions outlined at the time of the initial sale, such as flow rate (m<sup>3</sup>/hr)(GPM), pressure (bar)(PSI), temperature, chemical content of the wash fluid, cycle time, etc. If the Nozzle (8) size is too small and/or the opening at the bottom of the Stator (10) is too large, the Tee Housing (4) will not turn. Look for restrictions in the fluid supply such as a clogged filter, kinked hose, or deposits in the piping.

---

### Step 2

#### Tight Clearances

A recently overhauled Alfa Laval GJ 10 may fail to operate when first returned to service. If the machine seems otherwise fine, try running it with at least one Nozzle (8) removed. The reduction in pressure and additional flow will invariably be enough to overcome the extra resistance of new Bearings and Seals. Twenty minutes of operation should loosen the machine to run normally with the Nozzles reinstalled.

---

### Step 3

#### Debris Inside

Remove the Collar (8), and then lift out the Stator (9). Look for and remove any debris caught in the Stator (9) and the vanes of the Rotor (10). Remove any material wound around the Rotor Shaft (20). In addition, check for any debris caught in the outlet holes of the Stem (3), the nose of the Tee Housing (4), the Nozzle Housing (5), and the Nozzles (7).

---

## 5.3 Cleaning Solution Leakage

---

#### - **Worn Bearings and Seals**

Leakage from the Tee Housing (4) or Nozzle Housing (5) usually indicates worn Housing Bearings and Seals. Inspect them for wear (sealing lips are worn to a smooth surface) or damaged lips or loss of spring tension (indicated by excessive dry deposits of dirty or abrasive cleaning solution on the spring), and replace as required.

#### - **Worn Housing Cups**

Inspect the Housing Cups (23) and (21) for excessive wear (grooved or scored). Replace any that show distinct grooves.

#### - **Worn Collar O-rings**

Severe leakage between the Inlet Collar (9) and Cap (2) may indicate worn or damaged Collar O-rings (52) and (48). Remove the (9) as described in Section 6.3 – General Dismantling, and inspect the (52) and (48) for signs of damage or wear.

---

*Pay attention to possible faults  
Read the instructions carefully*

---

## 5.4 Poor Cleaning Performance

---

### - **Inadequate Flow and Pressure**

Check the pressure at the Alfa Laval Gamajet inlet under actual operating conditions. The supply piping and hoses must be large enough to handle the flow rate required for the nozzle size being used to ensure adequate pressure.

Insufficient pressure may also result from line losses when the machine is far from the pump. If this is the case, the line size must be increased accordingly for long runs. Although the Alfa Laval Gamajet will rotate at low flow rates, effective cleaning may require considerably more flow. Proper mechanical operation (the unit turns) is NOT the same thing as effective cleaning (the soils have been removed)! Contact Alfa Laval Gamajet Equipment if assistance is required.

### - **Chemical Concentration and Temperature**

Verify that the cleaning solution is the correct compound and in the concentration needed for the deposit being cleaned. If heating is necessary, also check that the solution is at the proper temperature.

### - **Plugged Nozzles**

Unscrew the Nozzles (8) and inspect for any debris.

### - **Slow or no Rotation of the Housings**

This will result in partial or erratic washing coverage. Refer to previous sections for more information.

### - **Alfa Laval GJ 10 Configuration**

Determine if the deposit being cleaned requires greater jet impact or longer jet dwell time (slower rotation) for more thorough scrubbing. Confirm that the Alfa Laval Gamajet nozzle size, turbine, and gearing are correct for the specific application. Refer to the machine's Birth Certificate for specific information regarding its configuration. Contact an Alfa Laval Gamajet Equipment representative if assistance is required.

### - **Inadequate Drainage**

Ensure that the vessel drains the effluent (used wash fluid) as fast as it's being sprayed in through the Alfa Laval Gamajet. The floor of the vessel should be sloped or pitched toward the drain and the drainage opening should be large enough to gravity-drain the effluent from the vessel. If you still have puddling (build-up of the wash fluid so it covers the floor and shields the residues underneath), use some form of pump to remove the effluent.

---



## 5 Operation

The Tank Cleaning machine is designed for cleaning in place (CIP). CIP = Cleaning In Place. Study the instructions carefully and pay special attention to the warnings! NaOH = Caustic Soda.  
HNO<sub>3</sub> = Nitric acid.

---

### 5.5 Recommended Cleaning

---

#### Step 1



Always handle lye and acid with great care.

Caustic danger!



Always use rubber gloves!



Always use protective goggles!

---

#### Step 2



Never touch the pump or the pipelines when sterilizing.

Danger of burns!

---

#### Step 3



Always rinse well with clean water after using a cleaning agent.

Always rinse!

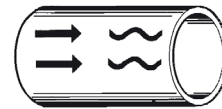

Clean Water

Cleaning agent

#### NOTE

Cleaning agents must be stored/disposed of in accordance with current regulations/directives.

---

*Maintain the Tank Cleaning Machine with care. Read the instructions carefully and pay special attention to the warnings!  
Always keep Minor spare parts kit in stock.*

---

### 6.1 General Maintenance

---

#### Step 1



Always read the technical data thoroughly. (see chapter 7 Technical Data)

---

#### Step 2

Recommended spare parts:

Order service kits from the service kits list

(See 8.10 Minor Service Kit & 8.11 Major Service Kit)

Ordering spare parts:

Contact your local Alfa Laval Sales company.

---

## 6 Maintenance

---

*Maintain the Tank Cleaning Machine with care. Read the instructions carefully and pay special attention to the warnings! Always keep Minor spare parts kit in stock.*

---

### 6.2 General Dismantling Setup

---

#### Step 1

##### Note

*A rigorously implemented preventative maintenance program will significantly reduce repair costs over the life of the Alfa Laval Gamajet. The foundation of such a program is regularly scheduled inspections to discover and replace worn or damaged parts before they can cause the failure of other, more costly, components. The inspection intervals required will depend on the severity of the application, but a complete internal inspection at 100 hours of operation is recommended initially.*

---

#### Step 2

##### Storage

The Alfa Laval Gamajet should be washed out with clean water after each use to remove any foreign material or soft substances left in the machine that may harden during storage and cause the Alfa Laval Gamajet to seize or lock up. A clean water rinse through the Alfa Laval Gamajet will also wash out any residues of chemical cleaners or recirculated wash water that could adversely affect the O-rings during prolonged contact in storage. The best position to store the machine is to stand it up with the inlet connection facing down.

---

#### Step 3

##### External Inspection Intervals

Before every shift, the Stator (10) and the Nozzles (8) should be inspected for debris. Examine the (10) by loosening the Collar Set Screw (27), while holding on the flats of the Cap (2), remove the main section of the machine from the Inlet Collar (9). Look into each Nozzle (8) for signs of debris or build-up. When using the UST Lance, inspect the lanyard wire and rubber plug for deterioration. Replace as needed.

---

#### Step 4

##### Internal Inspection Intervals

An interval of 100 hours is recommended initially. If all of the components are found to be in acceptable condition after the first 100 hours, the Alfa Laval Gamajet may then be inspected and routine preventive maintenance should be performed every 500 to 700 hours of operation, depending on the severity of use.

---

#### Step 5

##### Tips

All the Bearings, Bushings, Seals and O-rings are wear parts. Ideally, they should all be replaced, as a group, every 500 to 700 hours of operation, depending on the severity of use. If just one Bearing or Seal is worn or damaged, replace both it and its mate, not just the worn or damaged part.

---

---

*Read the instructions carefully. The items refer to the parts list and service kits section.*

---

### 6.3 General Dismantling

---

#### Step 1

##### Inlet Collar

If used, loosen the Grounding Set Screw (33) with a 5/64" Hex Key, minimum 2 turns. Remove grounding / safety wire from loop.

Loosen the Collar Set Screw (27) with a 3/32" Hex Key, minimum 2 turns.

Remove the Inlet Collar (9) and Stator (10).

**Warning: Hold or turn on Stem (3). DO NOT hold or turn on Tee Housing (4) or Tee Housing Cap (13). Doing so will damage the Geartrain (drawing 10).**

---

#### Step 2

##### Nozzle Housing

Unscrew the Nose Plate Screws (28) with a 1/4" slotted screwdriver.

Pull the Nozzle Housing (drawing 19) from the nose of the Tee Housing (4).

Remove the inner Nozzle Housing Seal (25) and Bearing (22).

---

#### Step 3

##### Cap and Geartrain

Using pliers on the flats of the Cap (2), unthread it from the body (drawing 15).

**Warning: Hold or turn on Stem (3). DO NOT hold or turn on Tee Housing (4) or Tee Housing Cap (13). Doing so will damage the Geartrain (drawing 10).**

Pull the Geartrain (drawing 10) from the remainder of the body.

---

#### Step 4

##### Body Assembly

Unthread the Tee Housing Cap (13) from the Tee Housing (drawing 12). **Note:** This is a **Left Hand** thread.

Remove the Stem Screws (26) with a 5/32" Hex Key, and Stem Base (drawing 13) from the Tee Housing (drawing 12).

Remove the Tee Housing (drawing 12) by pulling it from the Stem (drawing 11). The upper Tee Housing Seal (24) and Bearing (20) will pull off with the Tee Housing (drawing 12).

Remove the lower (24), (20) and Bevel Gear (drawing 14).

---

## 6 Maintenance

---

*Read the instructions carefully. The items refer to the parts list and service kits section.*

---

### 6.4 Inspection and Service of Components

---

#### Drawing 22

##### Inlet Assembly

Inspect the trough holes of the Stator (10) to be sure that they are clear.

---

#### Drawing 16

##### Collar O-rings

Inspect the Small and Large Collar O-rings, (52) and (48), for damage (clipped or cut) or deterioration (compression set or hardening) and replace if necessary.

Inspect the Collar-Stem O-ring (49) for damage (clipped or cut) or deterioration (compression set or hardening) and replace if necessary.

---

#### Drawings 4-10

##### Planetary Geartrain Assembly

##### *General Disassembly and Inspection*

**Tip: Disassemble the Planetary Gear Train Assembly (drawing 10) over a container or a confined space. There are several small components inside of the Gear Train, which may spill out if you are unfamiliar with its contents.**

Turn to drawing 10: Pull the Output Shaft (11) from the Gearhead Housing (drawing 8)

Unscrew the Input Shaft Nut (59) with an 11/32" socket and remove it with the Input Shaft Lockwasher (58) from the geartrain.

Remove the Rotor #E-810 (Step 8). If needed, use a slotted screwdriver for assistance.

Turn to drawing 9: Ensure the Input Shaft Carbide (41), pressed into Rotor (35), protrudes slightly, and is not chipped or cracked.

Turn to drawing 8: Pull and twist the Gearhead Lower Bearing Housing (18; drawing 7) and Input Shaft Upper Bearing Housing (17; drawing 1) from the Gearbox (1; drawing 6).

If the Gearbox Seals (39) did not come out of the (1) when the (18) and (17) were removed, remove them at this time. **Warning: To reduce the likelihood of scratching any sealing surface, use a pick made from brass.** Inspect the (39) for loss of spring tension (indicated by excessive dry deposits of dirty or abrasive cleaning solution on the spring), replace as required.

Turn to drawing 6: Using a #2 Phillips screwdriver, unscrew the Gearhead Short Screws (47) from the Gearbox (1).

Remove the Planetary Gearhead (drawing 5) from (1) by pushing on its output shaft.

##### *General Internals*

**Tip: To prevent the internal components of the Planetary Gearhead from unexpectedly spilling out, make sure that all steps are done with the input side of the assembly facing up.**

Using a #1 Phillips screwdriver, unscrew the Planetary Gearbox Screws (31) from the Planetary Gearhead (12).

Remove the Input Shaft Lower Bearing Housing (40) from the (31).

**Warning: If you suspect that the Planetary Gearhead (12) requires service, proceed with caution. If at any time you do not feel completely comfortable servicing (12), contact Alfa Laval Gamajet Equipment immediately.**

Using a needle nose pliers carefully remove the internal components of the (12). Examine the gears of the four different stages for any worn or broken teeth. Also, examine the Main Ring Gear (67) for bent or sharp teeth. If any damage is found, contact Alfa Laval Gamajet Equipment immediately.

The Bottom and Top Stage Planetary Gears (61) and (60) must be reinstalled in their respective locations. The Mid-Stage Planetary Gears (62) are interchangeable, however.

During reassembly, Alfa Laval Gamajet Equipment recommends the Gearhead Assembly (drawing 4) be lightly repacked using food-grade grease. Please contact Alfa Laval Gamajet Equipment for a specific grease recommendation.

---

*Read the instructions carefully. The items refer to the parts list and service kits section.*

---

### Drawings 1-3

#### Input Shaft and Housing

Turn to drawing 3: Inspect the Input Pinion (56) for hairline cracks on the end face or for worn, damaged, or sharp/pointed teeth. The (56) should be tight to the Input Shaft (36) and the Input Shaft Washer (43). The (43) should not be able to spin on the (36). Press the (56) back onto the (36) if it has slipped, or replace if cracked or worn.

Check for signs of scoring and wear on the (36). Replace if the coating has been chipped or cracked.

Turn to drawing 2: Inspect the Input Shaft Seal (51) inside the Input Shaft Lower Bearing Housing (40) for wear by placing the (36) back through it. There will be drag if the (51) is still good. If it needs to be replaced, pry out the old (51) using a brass pick, and replace it with a new one. Ensure that the seal is as square as possible to the (40) when installing it. The internal spring should be up and visible. **Tip:** Use a soft object, such as a pencil's eraser, to apply even pressure when installing (51).

Check the Input Shaft Lower Bearing Housing O-ring (57) and Static Seal (37) for deterioration or damage, replace (using a brass pick to remove the old components) if necessary. The (37) should be installed so its internal spring is up and visible.

Turn to drawing 1: The Gearbox Pin (54) should be firmly pressed into the Input Shaft Upper Bearing Housing (17).

The Input Shaft Carbide (41) in the (17) should protrude slightly. In addition, its running surfaces should be smooth, flat, and free of chips and cracks.

---

### Drawings 7, 10

#### Gearhead Lower Bearing Housing and Output Shaft

Turn to drawing 10: Check the Output Shaft (11) for signs of scoring or wear, especially in the area of contact with the Output Shaft Upper Seal (38). Replace if worn.

Turn to drawing 7: Examine the (38) for loss of spring tension (indicated by excessive dry deposits of dirty or abrasive cleaning solution on the spring). Also, ensure that it still has interference with the (11) by passing the (11) through the center of the in-place (38). There will be a noticeable drag if the seal is still good. If the (38) must be replaced, remove the Output Shaft Retaining Ring (45) using a small slotted screwdriver. Pry out the old (45) using a brass pick, and replace it with a new one. Ensure that the seal is square to the Gearhead Lower Bearing Housing (18) when installing it. The new (38) should be installed with the spring facing out and visible after it is installed. Reinstall the (45).

---

### Drawings 17-21

#### Nozzle Housing

Turn to drawing 19: Unscrew the Nozzle Housing Taper Cap Screws (30) with a 5/32" hex key.

Pull the Nozzle Housing Taper Cap (6) from the Nozzle Housing (drawing 17). Inspect the (6) for excessive damage. If it is no longer protecting the Nozzles (8), replace it.

Unscrew the Nozzles (8) with pliers and inspect for debris caught on the Stream Straightener (32) or in the nozzle orifice. The inside diameter of (8) must be smooth, round, and free of damage (especially any nicks) for maximum jet impact. Replace a worn or oversized (8) if the original flow rate and pressure are required.

Verify the (32) is tight in the bore of the (8).

Inspect the Nozzle O-ring (55) for compression set or deterioration. Replace, if needed.

Turn to drawing 17: Inspect the Nozzle Housing Bevel Gear (15) for wear such as sharp/pointed or worn teeth. If it needs to be replaced, remove the Nozzle Housing Bevel Gear Retaining Ring (16) with a small slotted screwdriver and pry the (15) from the Nozzle Housing (5).

Clean any deposits from the Nozzle Housing Cups (23) and examine for excessive wear. Light scoring is acceptable, but the (23) should be replaced if they are grooved in the seal contact area. A good maintenance program will require replacing many (23), therefore, it may be worthwhile to make or obtain press tools for pressing a (23) out of the (5). The press tools are available from Alfa Laval Gamajet Equipment. Before installing a new (23), clean the housing bores and remove any burrs resulting from (23) removal. Press them in so that their flanges are flush against the (5).

Turn to drawing 21: Inspect the Nozzle Housing Bearings (22) and Seals (25). Clean any deposits from the exterior of (22) and check their fit in the (23). While they should turn freely, (22) should be replaced if the thickness of the **flange is 0.086"**, or less, to avoid shortening the life of the Bevel Gears (14) and (15). Inspect the interior of (25) for loss of spring tension (indicated by excessive dry deposits of dirty or abrasive cleaning solution on the spring), replace as required.

---

## 6 Maintenance

---

### Drawings 12-15

#### Tee Housing and Tee Housing Cap

Turn to drawing 15: Check the water outlets on the nose of the Tee Housing (4); they should be free of debris.

Inspect the Tee Housing Bearings (20) and Seals (24). Clean any deposits from the exterior of (20) and check their fit in the Tee Housing Cups (21). While they should turn freely, a (20) should be replaced if the thickness of the **flange** is **0.095"**, or less, to avoid shortening the life of the Bevel Gears (14) and (15). Inspect the interior of (24) for loss of spring tension (indicated by excessive dry deposits of dirty or abrasive cleaning solution on the spring), replace as required.

Inspect the Tee Housing Cap O-ring (52) for compression set or deterioration. Replace, if needed.

Turn to drawing 14: Inspect the Tee Housing Bevel Gear (14) for worn, damaged or sharp/pointed teeth.

Ensure that the Bearing Locating Pin (34) is pressed firmly into (14).

Turn to drawing 12: Clean any deposits from (21) and examine for excessive wear. Light scoring is acceptable, but the Cups (21) should be replaced if they are grooved in the seal contact area. A good maintenance program will require replacing many (21), therefore, it may be worthwhile to make or obtain press tools for pressing a (21) out of the (4). The press tools are available from Alfa Laval Gamajet Equipment. Before installing a new (21), clean the housing bores and remove any burrs resulting from (21) removal. Press them in so that their flanges are flush against the (4).

Ensure that the Bearing Locating Pin (34) is pressed firmly into the (4).

---

### Drawings 11, 13

#### Stem and Stem Base

Turn to drawing 13: The Bearing Locating Pin (34) should be firmly pressed into the (19).

Turn to drawing 11: Inspect the water outlets of the Stem (3); they should be free of debris.

The Dowel Pin (50) should be firmly pressed into the (3).

Examine the Output Shaft Seal (53) for loss of spring tension (indicated by excessive dry deposits of dirty or abrasive cleaning solution on the spring). Also, ensure that it still has interference with the Output Shaft (11) by passing the (11) through the center of the (53). There will be a noticeable drag if the seal is still good. If the (53) must be replaced, pry it out using a brass pick, and replace it with a new one. The new (53) should be installed with the spring facing in and not visible after it is installed.

---

---

## 6.5 Reassembly

---

### General Notes

**All parts must be cleaned thoroughly before reassembling.** Any deposits remaining on the parts can cause difficult disassembly the next time the Alfa Laval Gamajet needs servicing. Also, it may cause misalignment of parts and the potential for premature failure.

Unless otherwise stated, apply a dab of a **Teflon-based anti-seize compound** to all threads when reassembling; this will prevent galling of threads and ease any future disassembly.

To ease installation of all O-rings, they should be lubricated prior to reassembly. Lithium-based soap grease is acceptable, for Viton® O-rings; however, a Silicon based lubricant must be used for EPDM O-rings.

---

### Drawings 5, 6, 8, 10

#### Gear Train

Turn to drawing 5: Insert the Planetary Gearbox Screws (31) through the Planetary Gearhead (12).

Push the Input Shaft (drawing 3) through the Input Shaft Lower Bearing Housing (drawing 2).

While installing the (drawing 2) onto the (12), ensure the Input Pinion (56) meshes properly with the top layer of gears.

Using a #1 Phillips, screw the (31) into the (drawing 2).

Turn to drawing 6: Install the Gearhead (drawing 5) back into the Gearbox (1).

After aligning the screw holes, thread the Gearhead Short Screws (47) back into the (drawing 5) using a #2 Phillips screwdriver. Make hand tight.

Turn to drawing 8: Install the Gearbox Static Seals (39) into the Gearbox (drawing 6). The internal spring of the (39) should be face out and be visible.

Install the Input Shaft Upper and Lower Bearing Housing (drawing 1) and (drawing 7) into the proper ends of the Gearbox (drawing 6) by using equal pressure around parts. They will snap into place.

Turn to drawing 10: Place the Rotor (35; drawing 9) over the end of the Input Shaft (36).

Install the Input Shaft Lockwasher (58) and Nut (59) using an 11/32" socket. Hold the (35) stationary with a pair of pliers while tightening the (59).

Place the Output Shaft (11) into the output side of the Geartrain (drawing 10). Ensure the slot of the (11) is aligned with the flats on the Gearhead's shaft.

---

### Drawing 15

#### Body Assembly

Slide the Tee Housing Bevel Gear (14; drawing 14) over the end of the Stem (3; drawing 11). Align the hole in the (14) with the Dowel Pin (50).

Place the first Tee Housing Bearing (20) and Seal (24) (spring side up) onto the (3).

Push the Tee Housing (4; drawing 12) over it until it is flush and fully seated.

Install the second (24), spring side down, over the (3).

**Tip:** Now, Place the second Tee Housing Bearing (20) into the Stem Base (19; drawing 13), aligning its hole with the Bearing Locating Pin (34). Now, invert the (4)/(3) assembly and place it over the (20)/(19) assembly. This technique ensures correct alignment of (20) and (34). Apply pressure to the (19) to drive the (20) and (24) into the (4).

Align the through holes of the (19) with the threaded holes in the top of the (3). Using a 5/32" Hex Key, thread Stem Screws (26) and Stem Screw Lockwashers (46) into the (3). Tighten in a star pattern.

Thread the Tee Housing Cap (13) to the end of the (4). **Note:** This is a **Left-Handed** thread.

---

### Drawing 16

#### Geartrain Installation

Insert the Geartrain (drawing 10) from into the Body Assembly (drawing 15). Rotate the Tee Housing (4) until the Output Shaft (11) falls into the slot of the Tee Housing Cap (13).

Thread the Cap (2) into the Body Assembly (drawing 15). Be sure to use the flats provided on the (2). Tighten.

**Warning:** Hold or turn on Stem (3). **DO NOT** hold or turn on Tee Housing (4) or Tee Housing Cap (13). Doing so will damage the Geartrain (drawing 10).

---



## 6 Maintenance

---

### Drawing 21

#### Nozzle Housing

Place the first Nozzle Housing Bearing (22) and Seal (25) (spring side out) onto the nose of the Tee Housing (4). Ensure the Bearing Locating Pin (34) is aligned with the hole in the (22).

Push the Nozzle Housing Assembly (drawing 19) onto the nose of the (4).

**Rotate the Nozzle Housing Assembly (drawing 19) slightly to mesh the Bevel Gears (14) and (15). Failure to ensure that the Bevel Gears have properly mated could damage them.**

Place the (25) (spring side in) over the nose of the (4).

Install the second (22) into the Nose Plate (7; drawing 20). Ensure that the Bearing Locating Pin (34) aligns with the hole in the (22).

Using the (7)/(22) assembly, push the (25) into the annular space between the (4) and Nozzle Housing Cup (23).

Using a 1/4" slotted screwdriver, screw the Nose Plate Screws (28) and Washers (29) into the (4).

---

### Drawing 22

#### Completed Assembly

Rotate the Rotor (35) using a Hex Key. It should spin easily and its veins must not strike the walls of the Cap (2). Continue turning the (35) several dozen times. The Nozzles (8) and Tee Housing (4) will slowly rotate if everything has been assembled correctly.

Insert the Stator (10) into the (2).

Screw on the Inlet Collar (9) (hand-tight only), and tighten the Collar Set Screw (27) with a 3/32" Hex Key.

**Warning: Hold or turn on Stem (3). DO NOT hold or turn on Tee Housing (4) or Tee Housing Cap (13). Doing so will damage the Geartrain (drawing 10).**

If used, reattach the grounding/safety wire to the unit using the location provided. Tighten the Grounding Set Screw (33) using a 5/64" Hex Key.

---

*It is important to observe the technical data during installation, operation and maintenance.  
Inform personnel about the technical data.*

## 7.1 Technical Data

The Alfa Laval GJ 10 Tank Cleaning Machine is a highly efficient machine at a range of pressures and flows. The instruction manual is part of the delivery. Read the instructions carefully.

### TECHNICAL DATA

Lubricant ..... Food grade  
Max. throw length ..... 10.5m (35 ft.)

### Pressure

Working pressure ..... F2.75 – 20 bar (40 – 300 PSI)  
Recommended pressure ..... F3.5 – 18.5 bar (50 – 270 PSI)

### Cleaning Pattern

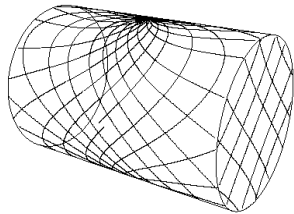

First Cycle

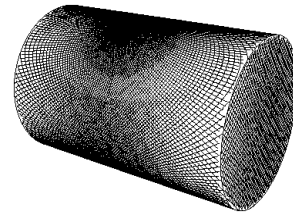

Full Pattern

The above drawings show the cleaning pattern achieved on a cylindrical horizontal vessel. The difference between the first cycle and the full pattern represents the number of additional cycles available to increase the density of the cleaning.

### Certificate

2.1 Material Certificate

### PHYSICAL DATA

#### Materials

1.4404 (316L), PPS, FKM, (EPDM and FKM available).

#### Temperature

Max. working temperature ..... 95°C (203°F)  
Max. ambient temperature ..... 140°C (284°F)

Weight ..... 4.3 kg (9.5 lbs.)

#### Connections

Standard thread ..... 1 ½" NPT, 1 ½" BSP

#### Options

Electronic rotation sensor to verify 3D coverage.

#### Caution

Do not use for gas evacuation or air dispersion.

## 7 Technical Data

*It is important to observe the technical data during installation, operation and maintenance.  
Inform personnel about the technical data.*

### 7.2 Performance Data

*It is important to observe the technical data during installation, operation and maintenance.  
Inform personnel about the technical data.*

#### Flow Rate

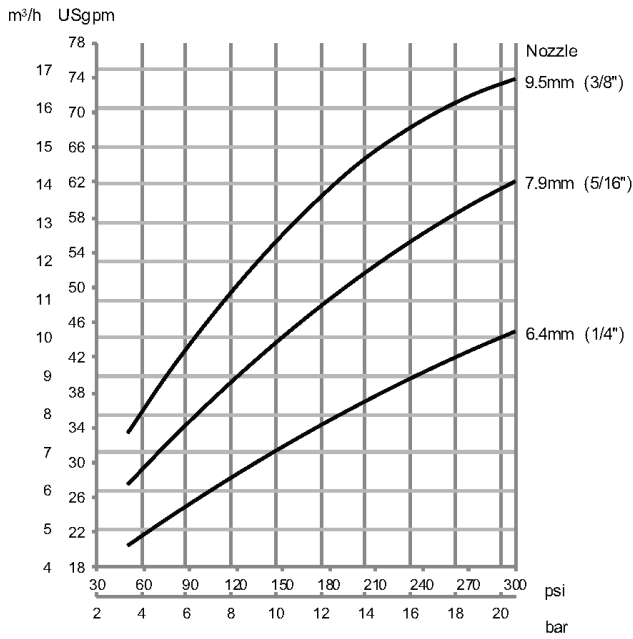

Inlet pressure

#### Impact Throw Length

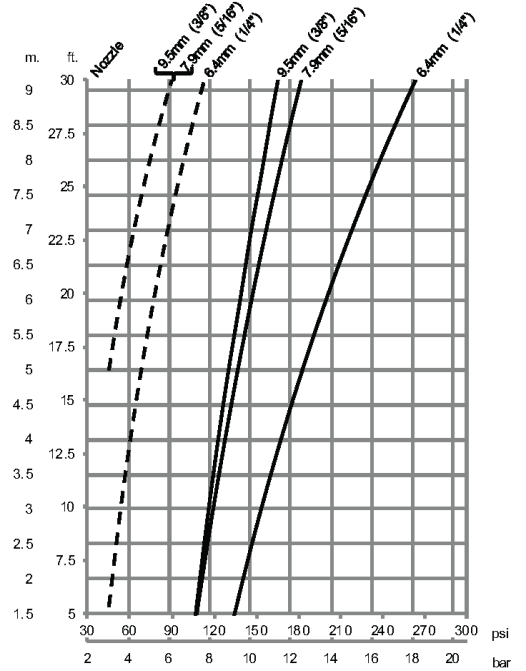

Inlet pressure

- - - Wetting, — Impact cleaning

#### Cleaning Time

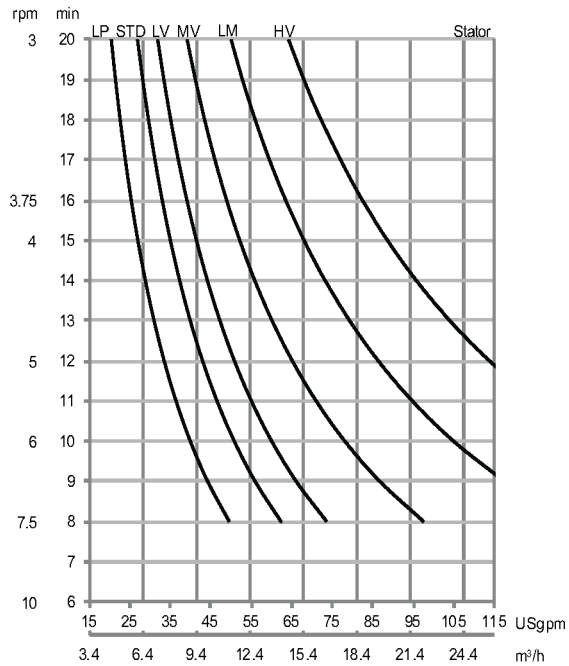

*It is important to observe the technical data during installation, operation and maintenance.  
Inform personnel about the technical data.*

7.3 Dimensions

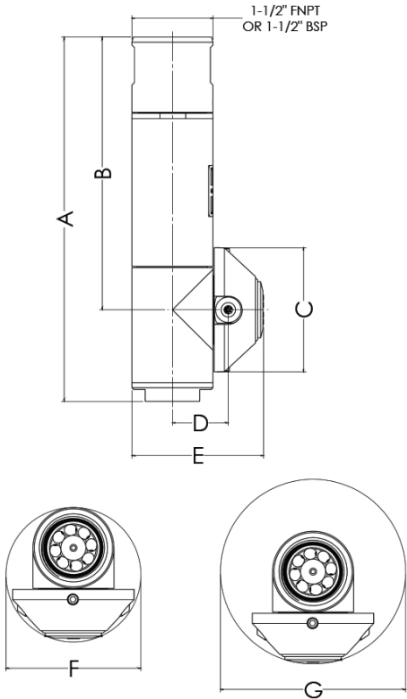

Dimensions

	A	B	C	D	E	F	G
mm	272	204	93	42	98	100	138
in	10.7	8	3.7	1.7	3.9	3.9	5.4

## 7 Technical Data

---

*It is important to observe the technical data during installation, operation and maintenance.  
Inform personnel about the technical data.*

---

### 7.4 Trax Simulation Tool

---

#### Standard Design

The choice of nozzle diameters can optimize jet impact length and flow rate at the desired pressure. As standard documentation, the Alfa Laval GJ 10 can be supplied with a "Declaration of Conformity" for material specifications.

#### TRAX Simulation Tool

TRAX is a unique software that simulates how the Alfa Laval GJ 10 performs in a specific tank or vessel. The simulation gives information on wetting intensity, pattern mesh width and cleaning jet velocity. This information is used to determine the best location of the tank cleaning device and the correct combination of flow, time, and pressure to implement.

A TRAX demo containing different cleaning simulations covering a variety of applications can be used as a reference and documentation for tank cleaning applications. The TRAX demo is free and available upon request.

#### Wetting Intensity

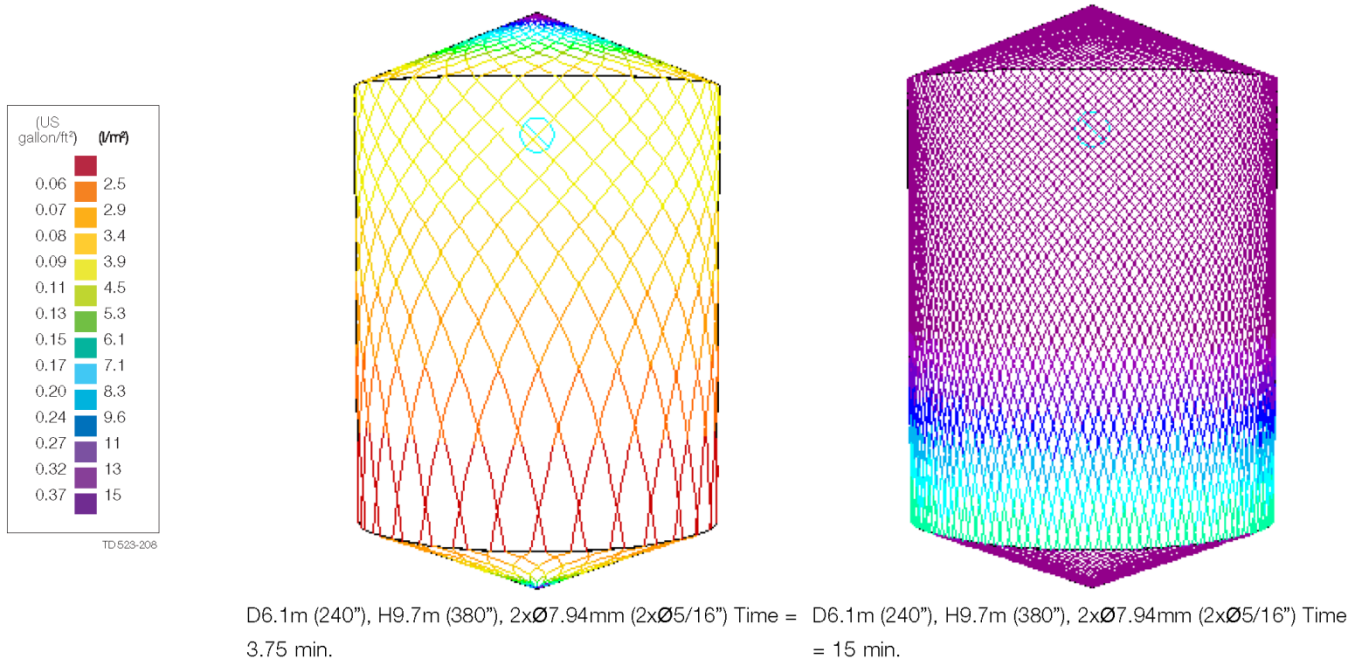

---

*The Drawing shows Alfa Laval GJ 10 Tank Cleaning Machine*

---

8.1 AL GJ 10 View

---

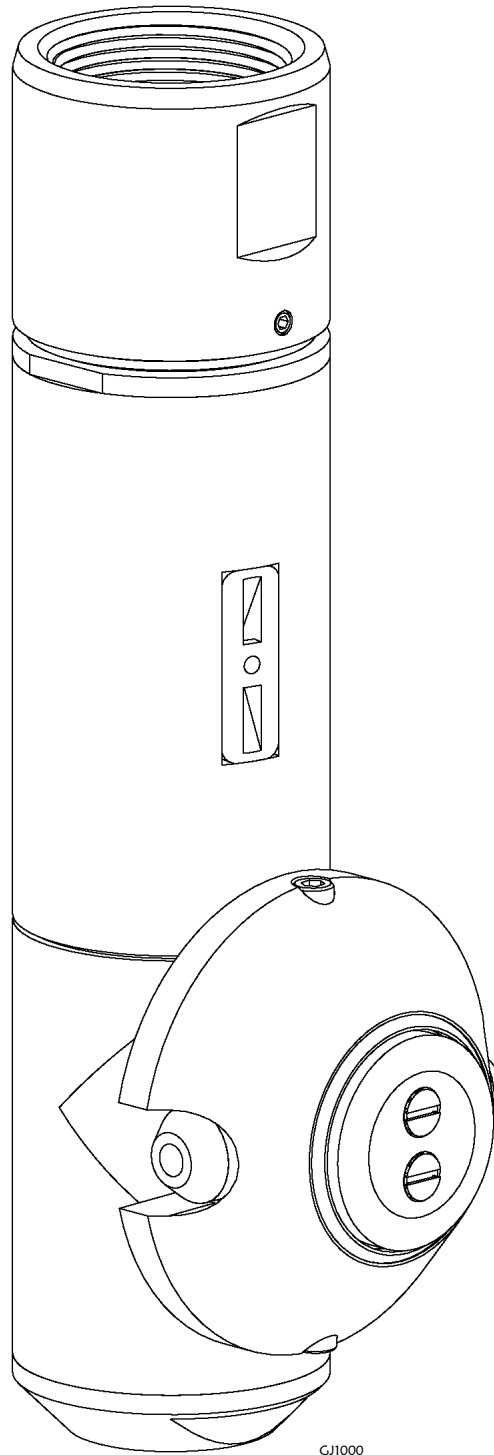

GJ1000

# 8 Parts List and Service Kits

The Drawing shows Alfa Laval GJ 10 Tank Cleaning Machine

## 8.2 Assembly Drawings – 1, 2, 3 & 4

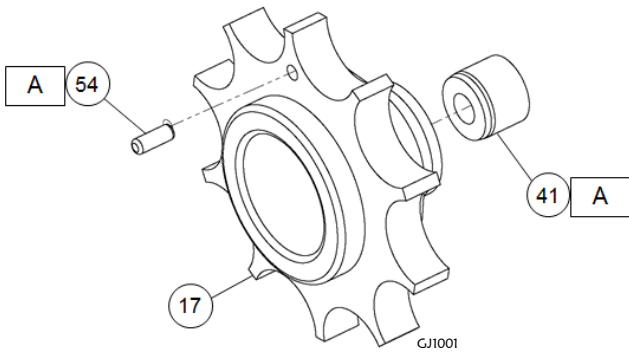

Drawing 1 – Input Shaft Upper Bearing Housing

A: Press Fit

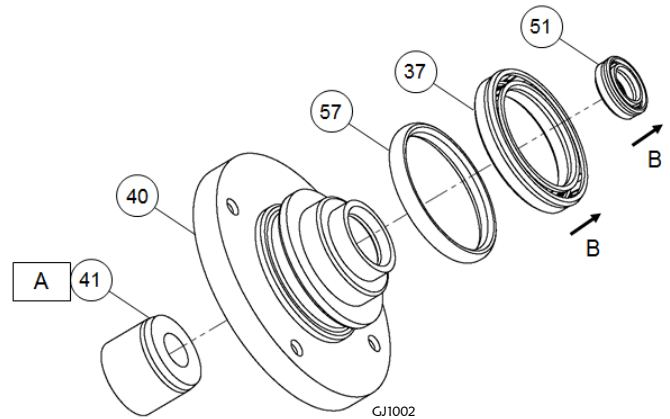

Drawing 2 – Input Shaft Lower Bearing Housing

A: Press Fit

B: Spring

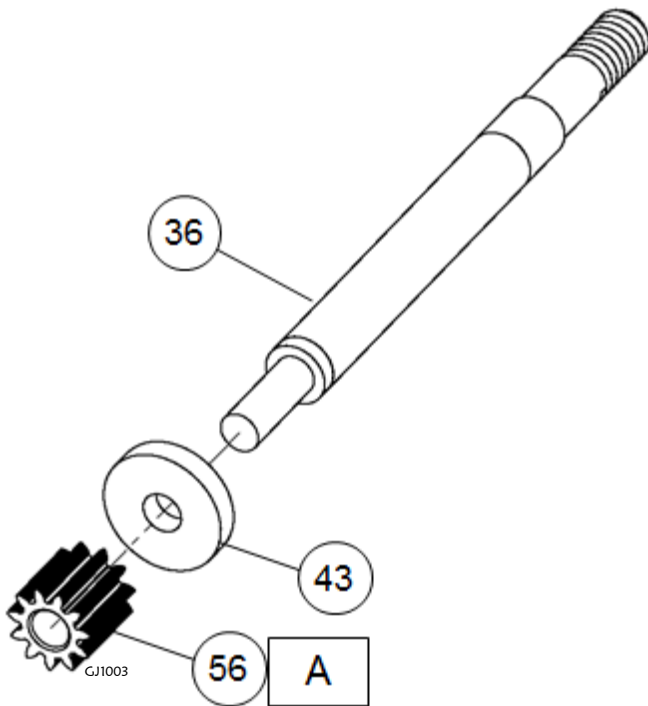

Drawing 3 – Input Shaft

Drawing 4 – Gearhead Assembly (12)

A: Press Fit

Note: The (56) must be completely perpendicular to the (36) or it will not press on correctly and damage the (56) or (36)

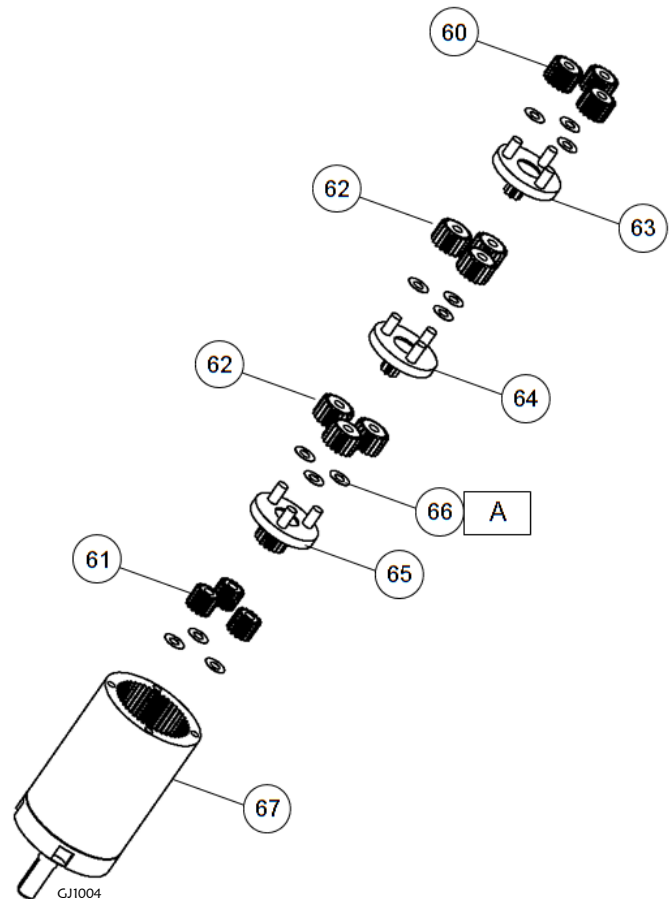

A: Typical

The Drawing shows Alfa Laval GJ 10 Tank Cleaning Machine

8.3 Assembly Drawings – 5, 6, 7, 8, 9 & 10

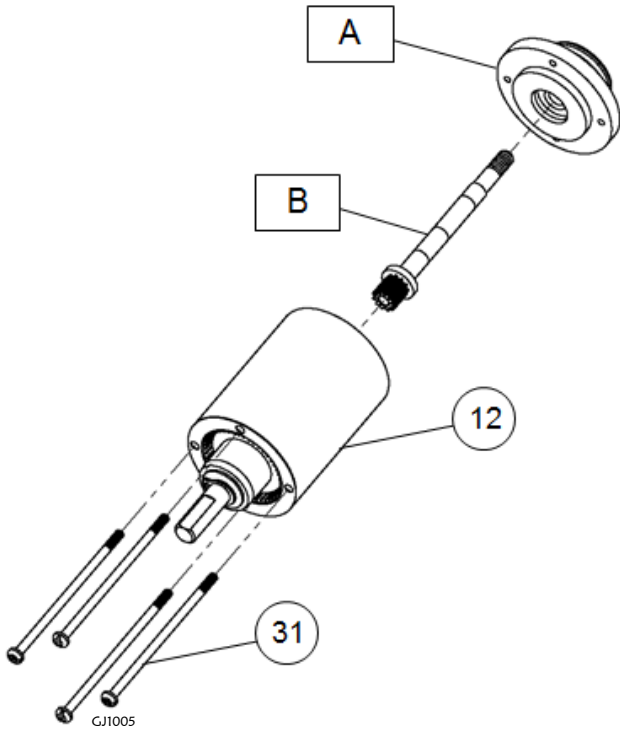

Drawing 5 – Gearhead

A: Drawing 2  
B: Drawing 3

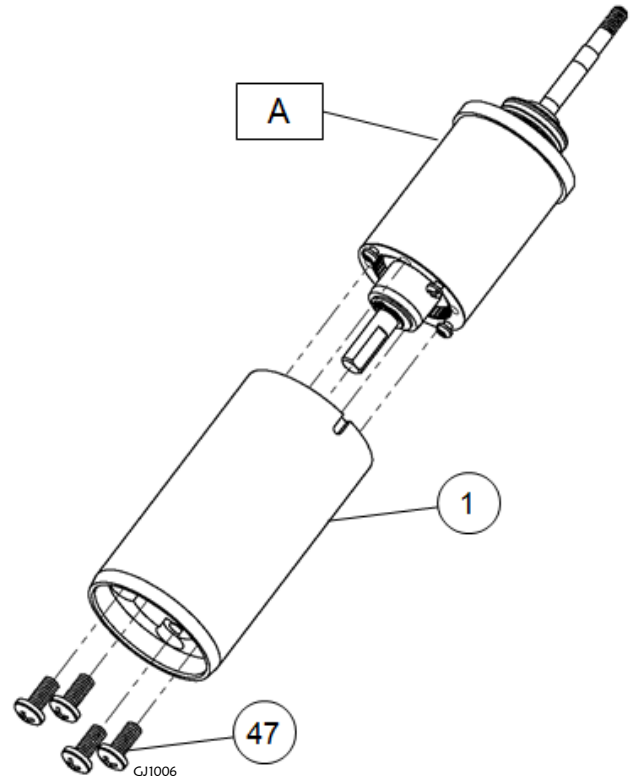

Drawing 6 - Gearbox

A: Drawing 5

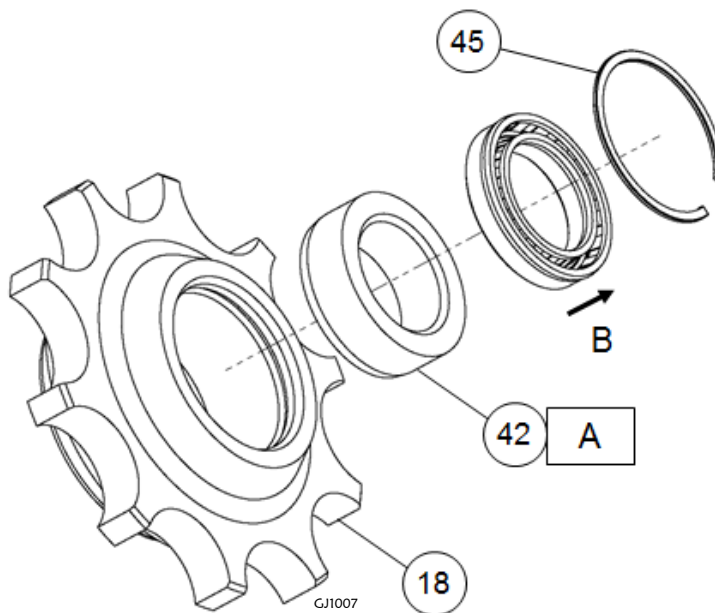

Drawing 7 – Gearhead Lower Bearing Housing

A: Press Fit  
B: Spring



## 8 Parts List and Service Kits

The Drawing shows Alfa Laval GJ 10 Tank Cleaning Machine

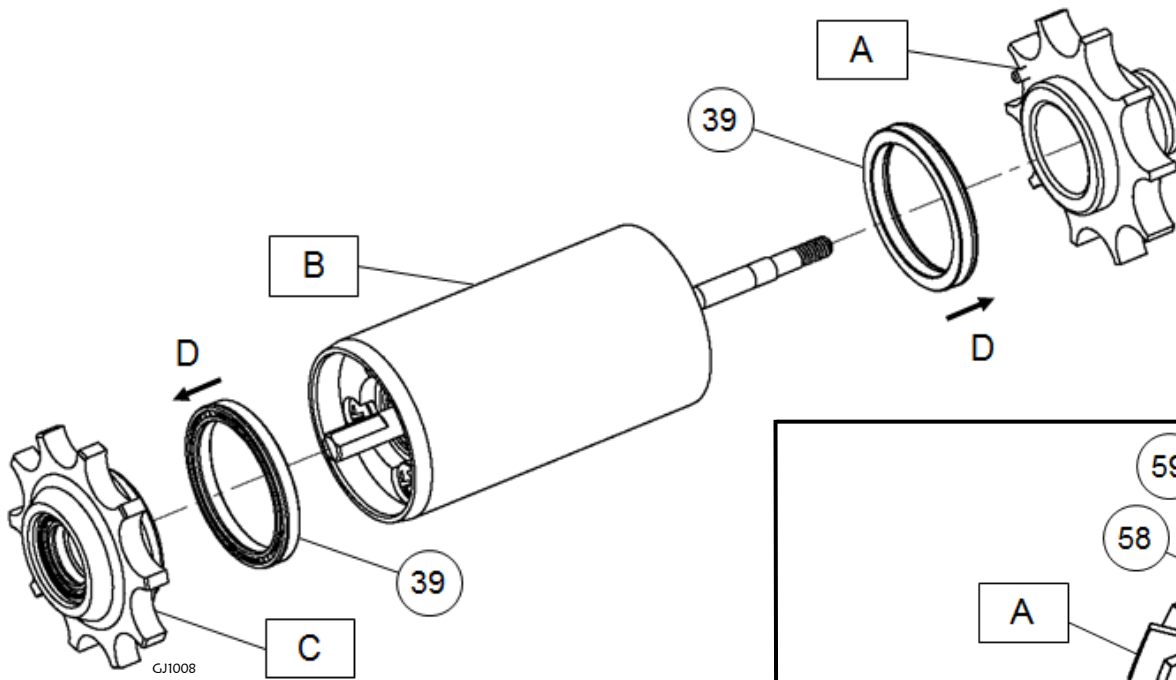

Drawing 8 – Geartrain Housing

- A: Drawing 1
- B: Drawing 6
- C: Drawing 7
- D: Spring

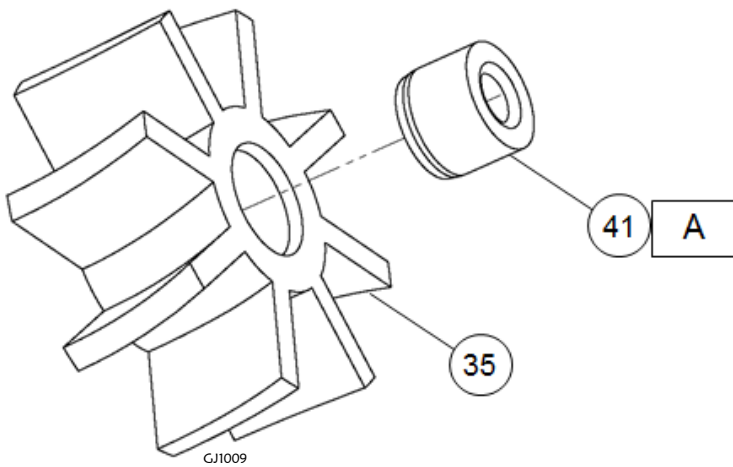

Drawing 9 – Rotor

- A: Press Fit

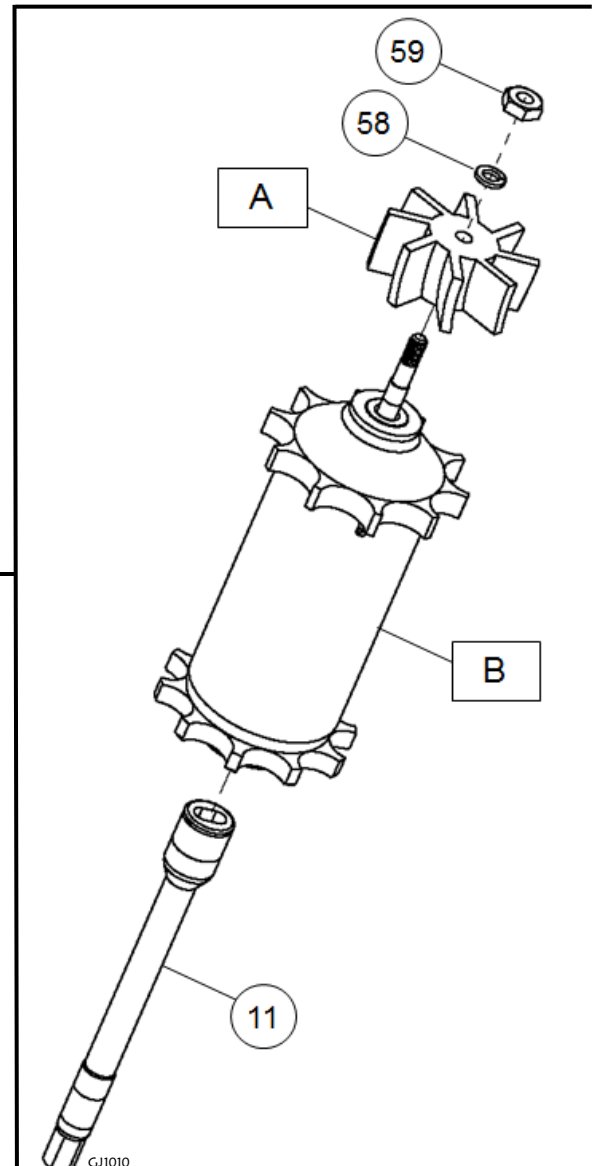

Drawing 10 - Geartrain

- A: Drawing 9
- B: Drawing 8

The Drawing shows Alfa Laval GJ 10 Tank Cleaning Machine

8.4 Assembly Drawings – 11, 12, 13, 14 & 15

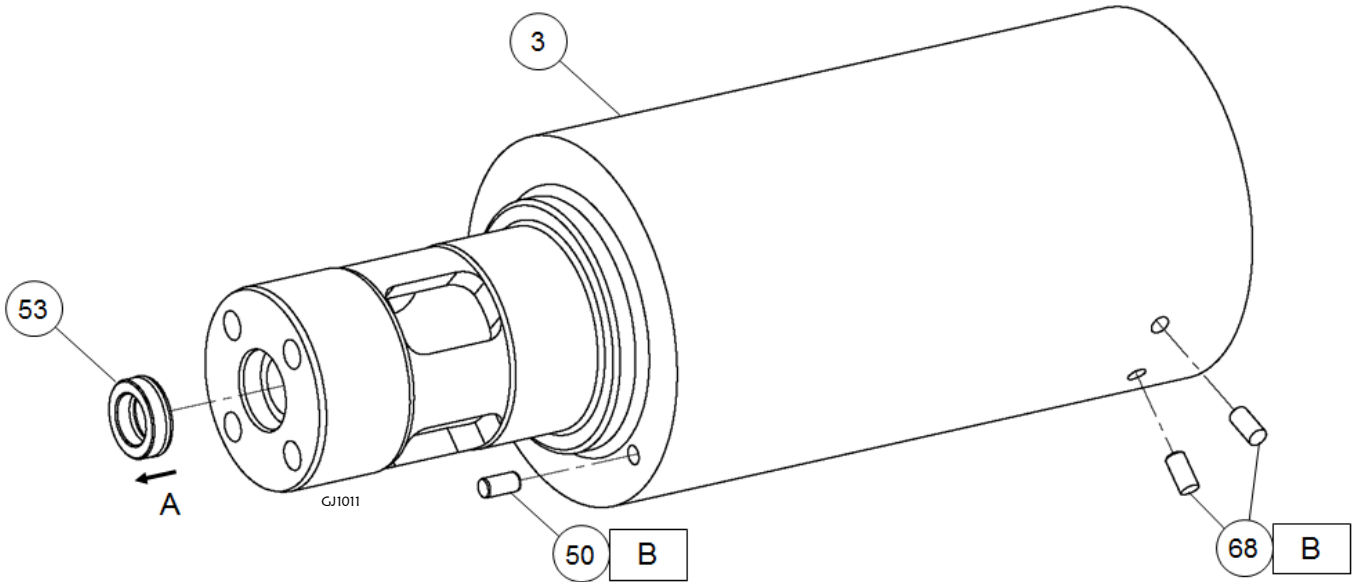

Drawing 11 – Stem

A: Spring  
B: Press Fit

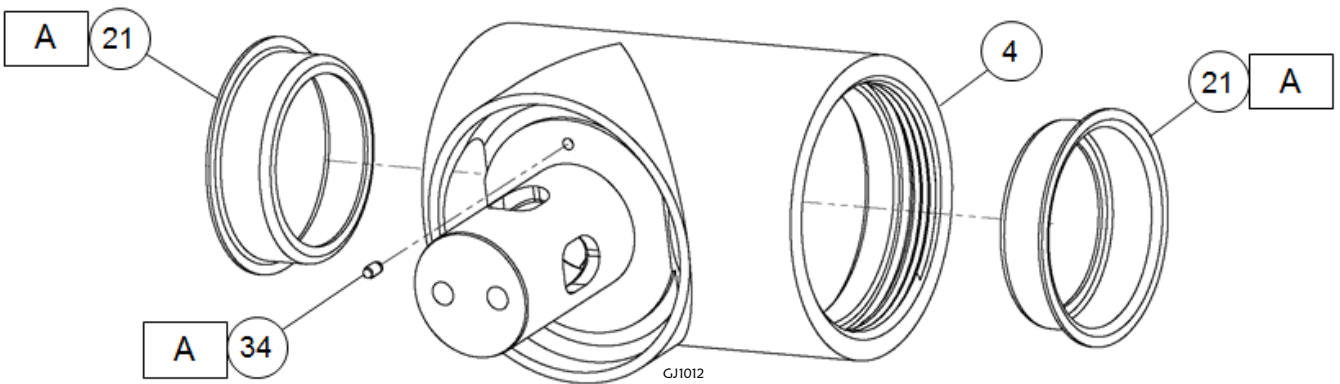

Drawing 12 – Tee Housing

A: Press Fit

# 8 Parts List and Service Kits

The Drawing shows Alfa Laval GJ 10 Tank Cleaning Machine

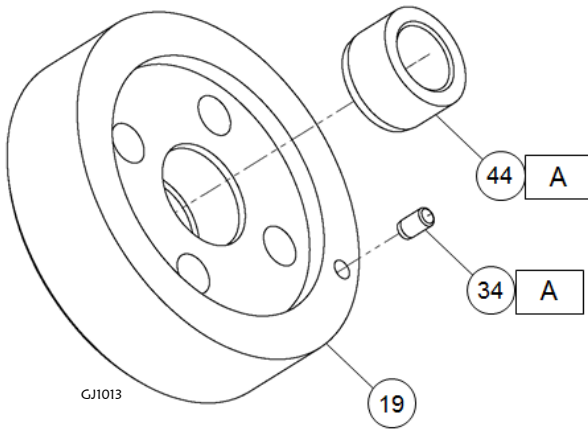

Drawing 13 – Stem Base

A: Press Fit

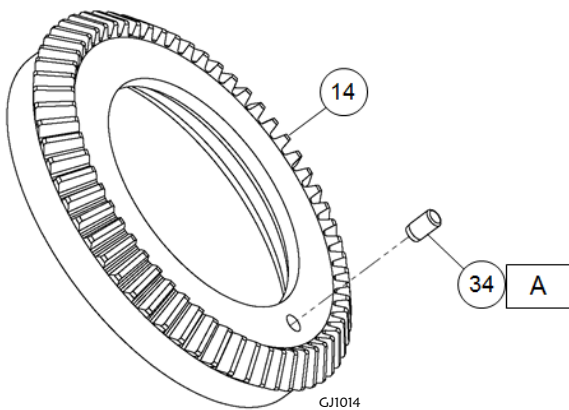

Drawing 14 – Tee Housing Bevel Gear

A: Press Fit

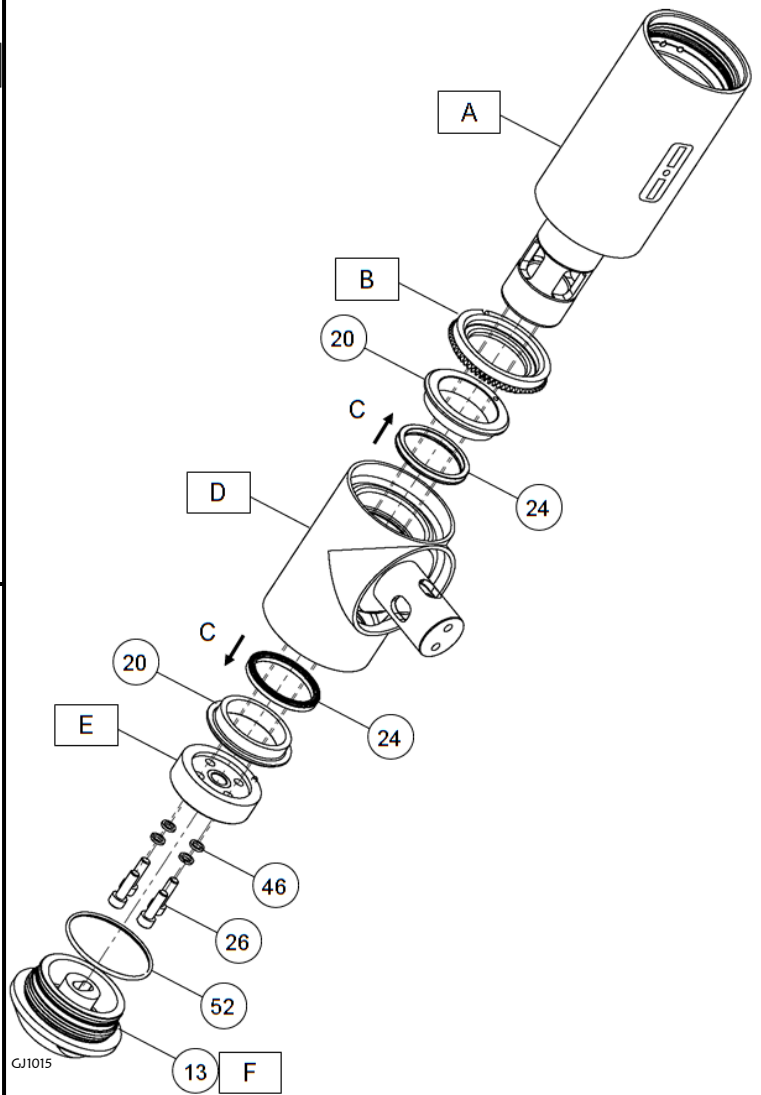

Drawing 15 – Body Assembly

A: Drawing 11  
 B: Drawing 14  
 C: Spring  
 D: Drawing 12  
 E: Drawing 13  
 F: Left-Handed Thread

The Drawing shows Alfa Laval GJ 10 Tank Cleaning Machine

8.5 Assembly Drawing – 16

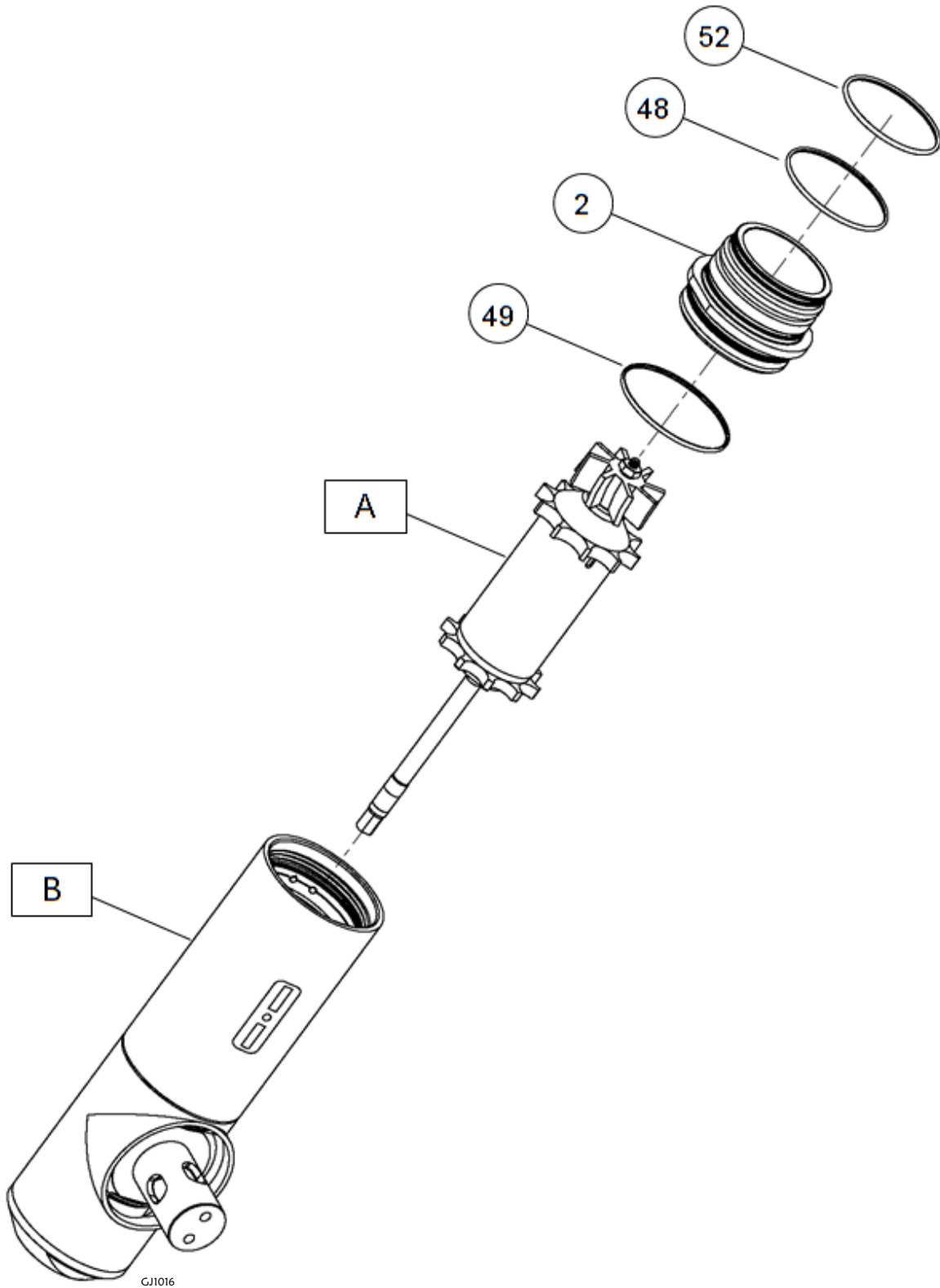

Drawing 16 – Install Geartrain and Cap

A: Drawing 10  
B: Drawing 15

## 8 Parts List and Service Kits

The Drawing shows Alfa Laval GJ 10 Tank Cleaning Machine

### 8.6 Assembly Drawings – 17, 18, 19 & 20

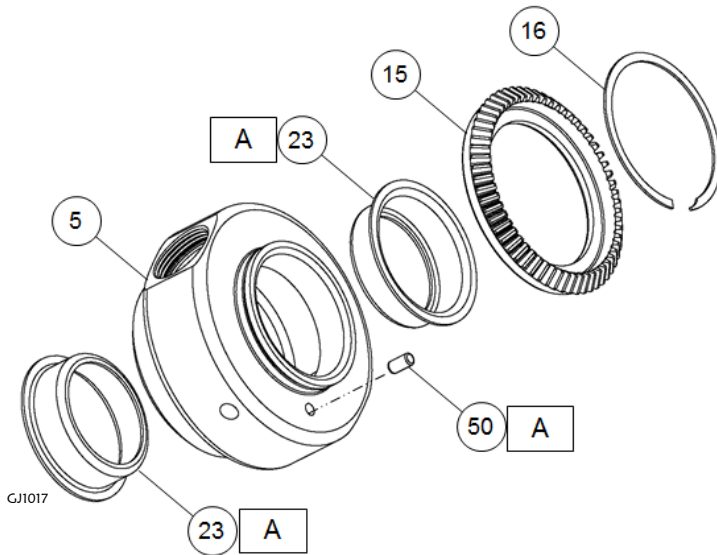

Drawing 17 – Nozzle Housing

A: Press Fit

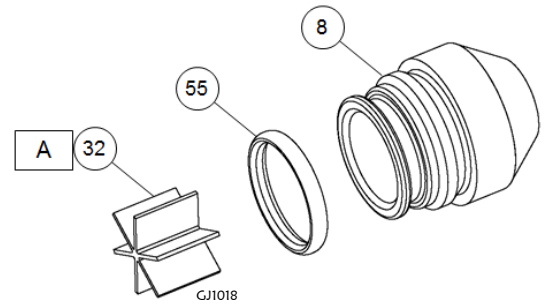

Drawing 18 - Nozzle

A: Part will stick out when installed

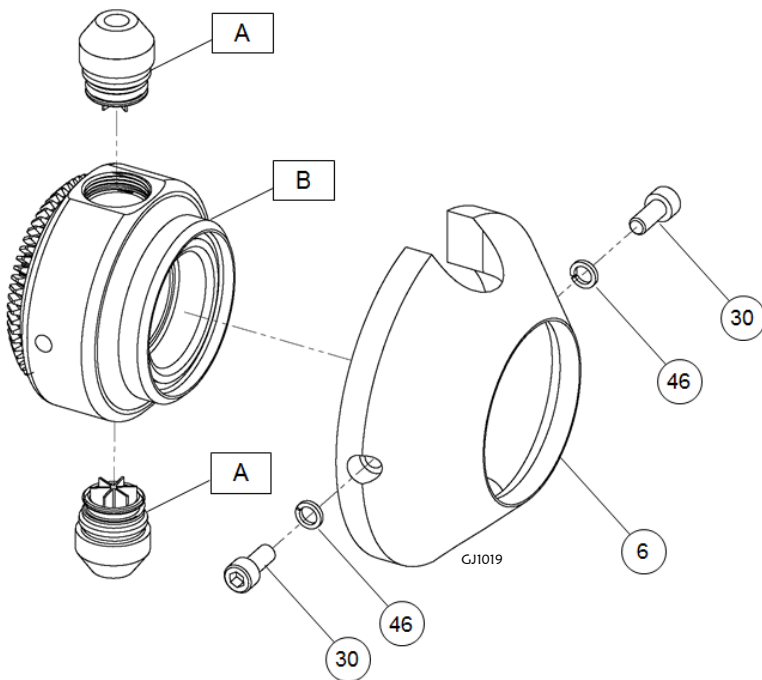

Drawing 19 – Nozzle Housing Assembly

A: Drawing 18  
B: Drawing 17

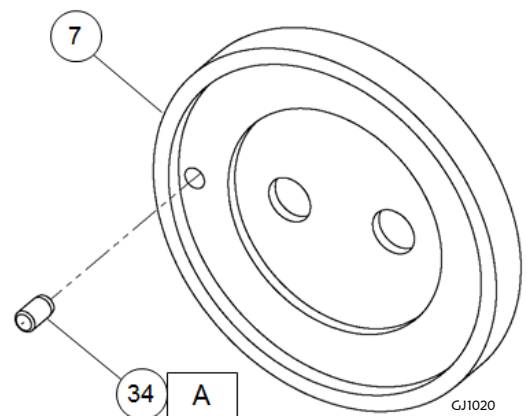

Drawing 20 – Nose Plate

A: Press Fit

The Drawing shows Alfa Laval GJ 10 Tank Cleaning Machine

8.7 Assembly Drawing – 21

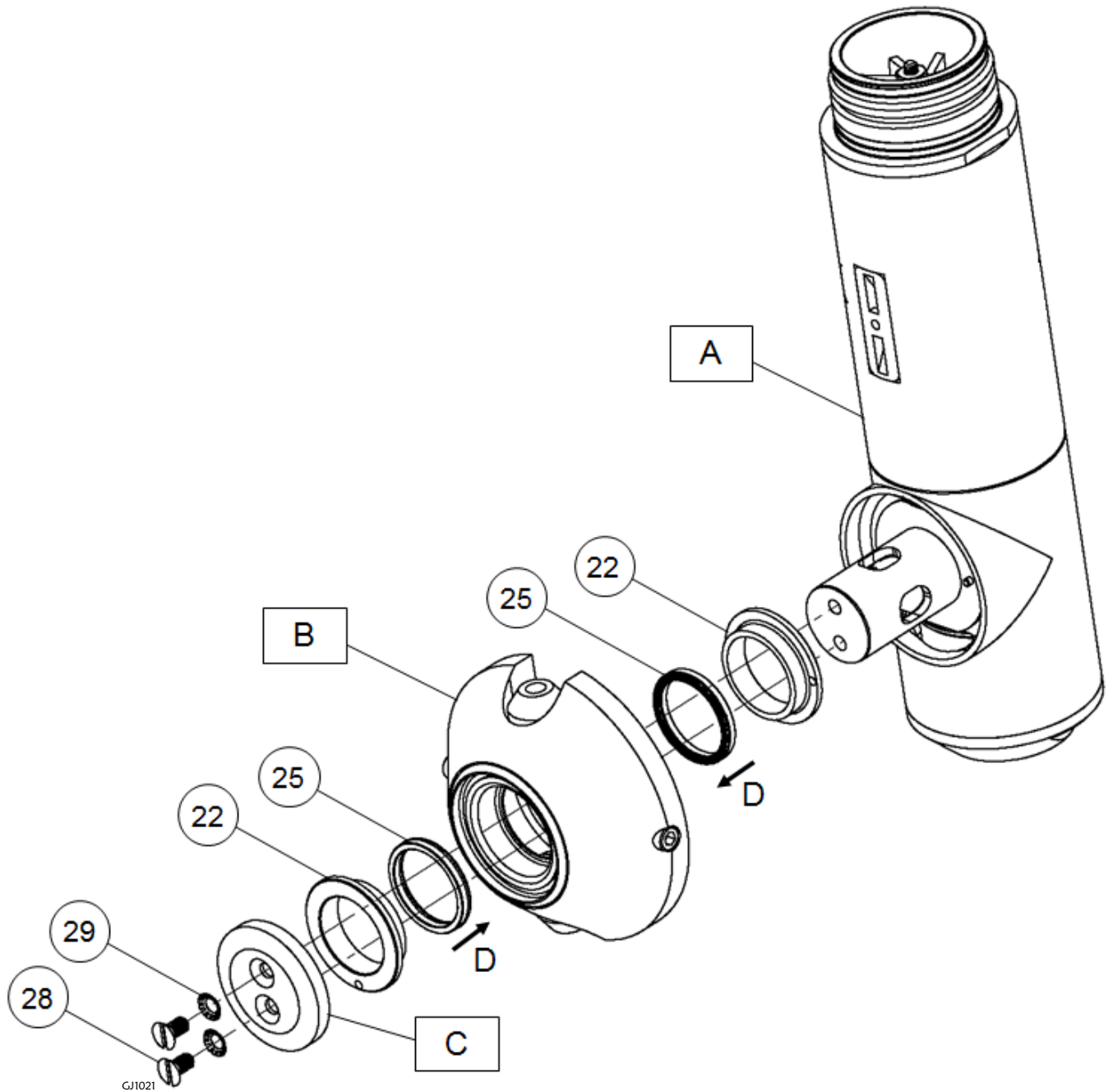

Drawing 21 – Install Nozzle Housing

- A: Drawing 16
- B: Drawing 19
- C: Drawing 20
- D: Spring

## 8 Parts List and Service Kits

The Drawing shows Alfa Laval GJ 10 Tank Cleaning Machine

### 8.8 Assembly Drawing – 22

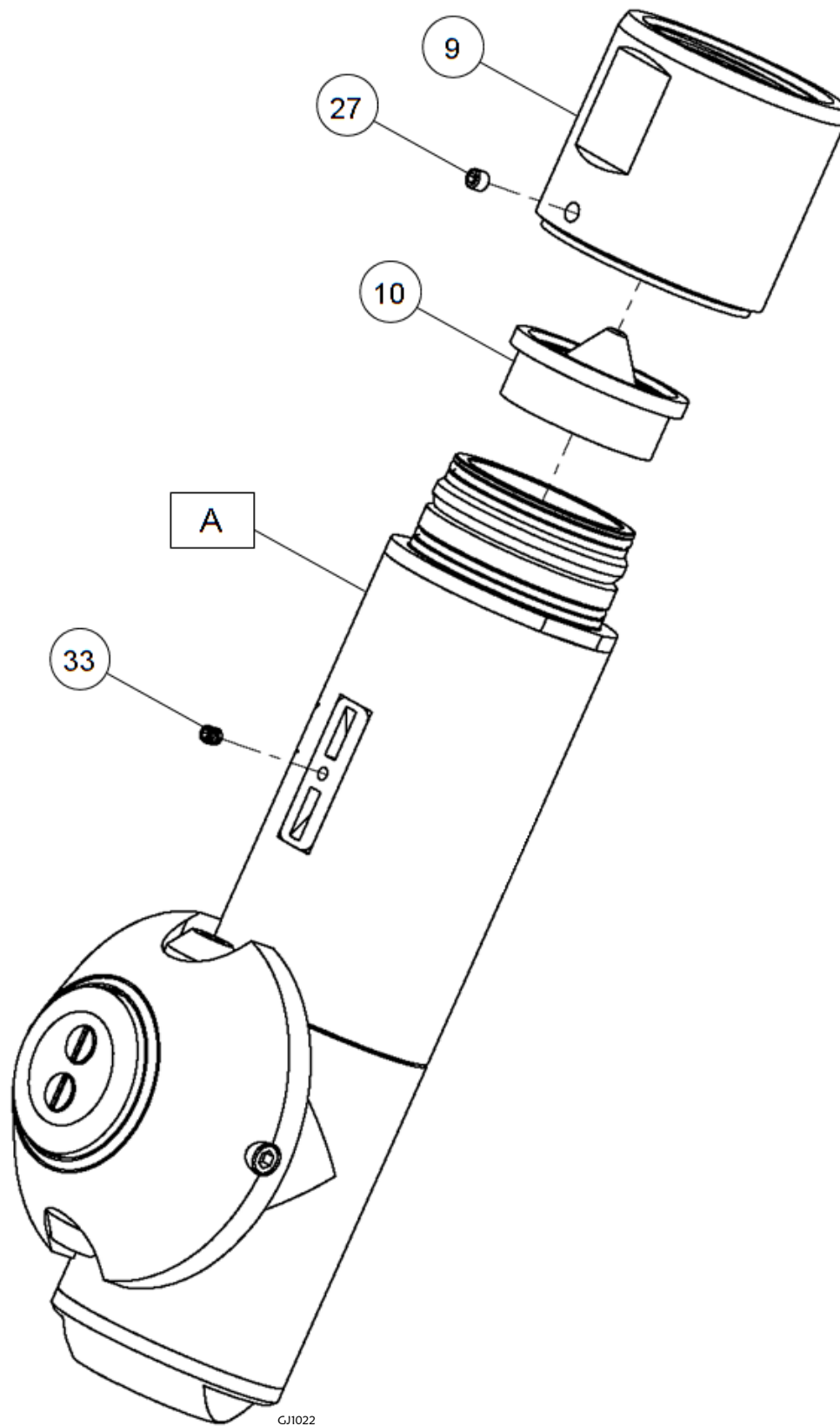

Drawing 22 – Completed Assembly

A: Drawing 21

## 8.9 Parts List

Pos.	AL No.	Gamajet No.	Description	No.
1	9614641001	10-101	Gearbox	1
2	9614641101	10-102	Cap	1
3	9614641201	10-103	Stem	1
4	9614641401	10-104	Tee Housing	1
5	9614641701	10-105	Nozzle Housing	1
6	9614642101	10-105-TC	Nozzle Housing Taper Cap	1
7	9614642201	10-106	Nose Plate	1
8.1	9614642403	10-107-3/8	Nozzle – 3/8”	2
8.2	9614642402	10-107-5/16	Nozzle – 5/16”	2
8.3	9614642401	10-107-1/4	Nozzle - 1/4”	2
9	9614642701	10-108	Inlet Collar	1
10.1	9614642805	10-109-STD	Stator - STD	1
10.2	9614605003	E-809-LV	Stator - LV	1
10.3	9614642804	10-109-MV	Stator - MV	1
10.4	9614642801	10-109-HV	Stator - HV	1
10.5	9614642803	10-109-LP	Stator - LP	1
10.6	9614642802	10-109-LM	Stator - LM	1
11	9614642901	10-112	Output Shaft	1
12	9614643101	10-113	Planetary Gearhead	1
13	9614643301	10-114	Tee Housing Cap	1
14	9614643501	10-117	Tee Housing Bevel Gear	1
15	9614643601	10-118	Nozzle Housing Bevel Gear	1
16	9614643701	10-119	Nozzle Housing Bevel Gear Retaining Ring	1
17	9614644101	10-128	Input Shaft Upper Bearing Housing	1
18	9614644301	10-129	Gearhead Lower Bearing Housing	1
19	9614644501	10-130	Stem Base	1
20	9614644601	10-131	Tee Housing Bearing	2
21	9614644801	10-132	Tee Housing Cup	2
22	9614644901	10-133	Nozzle Housing Bearing	2
23	9614645301	10-134	Nozzle Housing Cup	2
24	9614645401	10-135	Tee Housing Seal	2
25	9614645601	10-136	Nozzle Housing Seal	2
26	9614646201	10-146	Stem Screws	4
27	9614646601	10-150	Collar Set Screw	1
28	9614646701	10-151	Nose Plate Screw	2
29	9614646801	10-152	Nose Plate Washer	2
30	9614646901	10-153	Nozzle Housing Taper Cap Screws	2
31	9614647001	10-154	Planetary Gearbox Screw	4
32	9614647201	10-160	Stream Straightener	2
33	9614647401	10-163	Grounding Set Screw	1
34	9614647501	10-164	Bearing Locating Pin	4
35	9614605101	E-810	Rotor	1
36	9614607301	E-822	Input Shaft	1
37	9614607501	E-823	Input Shaft Bearing Housing Static Seal	1
38	9614607601	E-824	Output Shaft Upper Seal	1
39	9614607701	E-826	Gearbox Static Seal	2
40	9614607801	E-827	Input Shaft Lower Bearing Housing	1
41	9614609101	E-839	Input Shaft Carbide	3
42	9614609201	E-840	Output Shaft Upper Carbide Bearing	1
43	9614609301	E-841	Input Shaft Washer	1
44	9614609401	E-842	Output Shaft Lower Carbide Bearing	1
45	9614609501	E-843	Output Shaft Retaining Ring	1
46	9614609801	E-847	Stem & Taper Cap Screw Lockwasher	6
47	9614610401	E-853	Gearhead Short Screw	4
48.1	9614610801	E-862	Large Collar O-ring – Viton	1
48.2	9614610802	E-862-E	Large Collar O-ring – EPDM	1
48.3	9614610803	E-862-K	Large Collar O-ring – Kalrez	1
48.4	9614610804	E-862-T	Large Collar O-ring - Teflon	1
49.1	9614610901	E-863	Collar-Stem O-ring – Viton	1
49.2	9614610902	E-863-E	Collar-Stem O-ring – EPDM	1
49.3	9614610903	E-863-K	Collar-Stem O-ring – Kalrez	1



## 8 Parts List and Service Kits

49.4	9614610904	E-863-T	Collar-Stem O-ring - Teflon	1
------	------------	---------	-----------------------------	---

Pos.	AL No.	Gamajet No.	Description	No.
50	9614611101	E-866	Dowel Pin	1
51	9614611201	E-867	Input Shaft Seal	1
52.1	9614636801	7-458	Small Collar / Tee Housing Cap O-ring - EPDM	2
52.2	9614636802	7-458-K	Small Collar / Tee Housing Cap O-ring - Kalrez	2
52.3	9614636803	7-458-V	Small Collar / Tee Housing Cap O-ring - Viton	2
53	9614634001	7-150	Output Shaft Seal	1
54	9614627801	6-166	Gearbox Pin	1
55.1	9614662104	643-E	Nozzle O-ring - EPDM	2
55.2	9614662103	643-K	Nozzle O-ring - Kalrez	2
55.3	9614662102	643-V	Nozzle O-ring - Viton	2
55.4	9614662101	643-T	Nozzle O-ring - Teflon	2
56	9614674601	8-512	Input Pinion	1
57.1	9614677701	8-539	Input Shaft Lower Bearing Housing O-ring - Viton	1
57.2	9614677702	8-539-EP	Input Shaft Lower Bearing Housing O-ring - EPDM	1
57.3	9614677703	8-539-K	Input Shaft Lower Bearing Housing O-ring - Kalrez	1
58	9614678201	8-544	Input Shaft Lowckwasher	1
59	9614678301	8-545	Input Shaft Nut	1
60			Top Stage Planetary Gears (17 teeth)	3
61			Bottom Stage Planetary Gears (14 teeth)	3
62			Mid-Stage Planetary Gears (18 teeth)	6
63			Top Gearhead Carrier	1
64			Mid Gearhead Carrier	1
65			Bottom Gearhead Carrier	1
66			Planetary Gearhead Gear Washers	12
67			Main Ring Gear	1
68	9614647101	10-155	Stem Tapered Pin	2

## 8.10 Minor Service Kit

Article no: 9614689001 10VITONKIT ALFA LAVAL GJ 10 KIT - VITON				
Pos. no.	Part No.	Gamajet Part No.	Description	No.
20	9614644601	10131	GJ 10 TEE HOUSING BEARING	2 EACH
22	9614644901	10133	GJ 10 NOZZLE HOUSING BEARING	2 EACH
24	9614645401	10135	GJ 10 TEE HOUSING SEAL	2 EACH
25	9614645601	10136	GJ 10 NOZZLE HOUSING SEAL	2 EACH
37	9614607501	E823	GJ VIII RS STATIC SEAL	1 EACH
38	9614607601	E824	GJ VIII OS UPPER SEAL	1 EACH
39	9614607701	E826	GJ VIII GEARBOX STATIC SEAL	2 EACH
48.1	9614610801	E862	GJ VIII COLLAR STEM SM O-RING	1 EACH
49.1	9614610901	E863	GJ VIII COLLAR STEM LG O-RING	1 EACH
51	9614611201	E867	GJ VIII GEARHEAD SEAL	1 EACH
52.3	9614636803	7458K	HOUSING O-RING/COLLAR O-RING	2 EACH
55.3	9614662102	431162	643-K/VIII O-RING KALREZ	2 EACH
56	9614674601	8512	GJ V/VIII INPUT PINION	1 EACH
57.1	9614677701	8539	GJ V GB NS/VIII RSLBH O-RING	1 EACH

Article no: 9614689301 10KALREZKIT ALFA LAVAL GJ 10 KIT - KALREZ				
Pos. no.	Part No.	Gamajet Part No.	Description	No.
20	9614644601	10131	GJ 10 TEE HOUSING BEARING	2 EACH
22	9614644901	10133	GJ 10 NOZZLE HOUSING BEARING	2 EACH
24	9614645401	10135	GJ 10 TEE HOUSING SEAL	2 EACH
25	9614645601	10136	GJ 10 NOZZLE HOUSING SEAL	2 EACH
37	9614607501	E823	GJ VIII RS STATIC SEAL	1 EACH
38	9614607601	E824	GJ VIII OS UPPER SEAL	1 EACH
39	9614607701	E826	GJ VIII GEARBOX STATIC SEAL	2 EACH
48.3	9614610803	E862K	GJ VIII COLLAR STEM SM O-RING	1 EACH
49.3	9614610903	E863K	GJ VIII COLLAR STEM LG O-RING	1 EACH
51	9614611201	E867	GJ VIII GEARHEAD SEAL	1 EACH
52.2	9614636802	7458K	HOUSING O-RING/COLLAR O-RING	2 EACH
55.2	9614662103	431162	643-K/VIII O-RING KALREZ	2 EACH
56	9614674601	8512	GJ V/VIII INPUT PINION	1 EACH
57.3	9614677703	8539K	GJ V GB NS/VIII RSLBH O-RING	1 EACH

## 8 Parts List and Service Kits

### 8.11 Major Service Kit

Article no: 9614689101 10VITONMAJKIT ALFA LAVAL GJ 10 MAJOR KIT - VITON				
Pos. no.	Part No.	Gamajet Part No.	Description	No.
20	9614644601	10131	GJ 10 TEE HOUSING BEARING	2 EACH
22	9614644901	10133	GJ 10 NOZZLE HOUSING BEARING	2 EACH
24	9614645401	10135	GJ 10 TEE HOUSING SEAL	2 EACH
25	9614645601	10136	GJ 10 NOZZLE HOUSING SEAL	2 EACH
37	9614607501	E823	GJ VIII RS STATIC SEAL	1 EACH
38	9614607601	E824	GJ VIII OS UPPER SEAL	1 EACH
39	9614607701	E826	GJ VIII GEARBOX STATIC SEAL	2 EACH
48.1	9614610803	E862	GJ VIII COLLAR STEM SM O-RING	1 EACH
49.1	9614610901	E863	GJ VIII COLLAR STEM LG O-RING	1 EACH
51	9614611201	E867	GJ VIII GEARHEAD SEAL	1 EACH
52.1	9614636802	7458	HOUSING O-RING/COLLAR O-RING	2 EACH
53	9614634001	7150	OUTPUT SHAFT LOWER SEAL	1 EACH
55.3	9614662103	431160	643-K/VIII O-RING KALREZ	2 EACH
56	9614674601	8512	GJ V/VIII INPUT PINION	1 EACH
57.1	9614677703	8539	GJ V GB NS/VIII RSLBH O-RING	1 EACH
11	9614642901	10112	GJ 10 OUTPUT SHAFT	1 EACH
12	9614643101	10113	GJ 10 PLANETARY GEARHEAD	1 EACH
21	9614644801	10132	GJ 10 TEE HOUSING CUP	2 EACH
23	9614645301	10134	GJ 10 NOZZLE HOUSING CUP	2 EACH
36	9614607401	E822A	GJ VIII ROTOR SHAFT ASSEMBLY	1 EACH

Article no: 9614689401 10KALREZMAJKIT ALFA LAVAL GJ 10 MAJOR KIT - KALREZ				
Pos. no.	Part No.	Gamajet Part No.	Description	No.
20	9614644601	10131	GJ 10 TEE HOUSING BEARING	2 EACH
22	9614644901	10133	GJ 10 NOZZLE HOUSING BEARING	2 EACH
24	9614645401	10135	GJ 10 TEE HOUSING SEAL	2 EACH
25	9614645601	10136	GJ 10 NOZZLE HOUSING SEAL	2 EACH
37	9614607501	E823	GJ VIII RS STATIC SEAL	1 EACH
38	9614607601	E824	GJ VIII OS UPPER SEAL	1 EACH
39	9614607701	E826	GJ VIII GEARBOX STATIC SEAL	2 EACH
48.3	9614610803	E862K	GJ VIII COLLAR STEM SM O-RING	1 EACH
49.3	9614610903	E863K	GJ VIII COLLAR STEM LG O-RING	1 EACH
51	9614611201	E867	GJ VIII GEARHEAD SEAL	1 EACH
52.2	9614636802	7458K	HOUSING O-RING/COLLAR O-RING	2 EACH
53	9614634001	7150	OUTPUT SHAFT LOWER SEAL	1 EACH
55.2	9614662103	431162	643-K/VIII O-RING KALREZ	2 EACH
56	9614674601	8512	GJ V/VIII INPUT PINION	1 EACH
57.3	9614677703	8539K	GJ V GB NS/VIII RSLBH O-RING	1 EACH
11	9614642901	10112	GJ 10 OUTPUT SHAFT	1 EACH
12	9614643101	10113	GJ 10 PLANETARY GEARHEAD	1 EACH
21	9614644801	10132	GJ 10 TEE HOUSING CUP	2 EACH
23	9614645301	10134	GJ 10 NOZZLE HOUSING CUP	2 EACH
36	9614607401	E822A	GJ VIII ROTOR SHAFT ASSEMBLY	1 EACH

**How to contact Alfa Laval Tank Equipment:**

For further information, please feel free to contact:

Alfa Laval Tank Equipment

604 Jeffers Circle, Exton, PA 19341 USA

Tel switchboard: +01 610 408 9940 – Fax switchboard: +01 610 408 9945

[www.gamajet.com](http://www.gamajet.com), [www.alfalaval.com](http://www.alfalaval.com), customer service: [exton@alfalaval.com](mailto:exton@alfalaval.com)

contact details for all countries are continually updated on our websites.

© Alfa Laval Corporate AB

This document and its contents is owned by Alfa Laval Corporate AB and protected by laws governing intellectual property and thereto related rights. It is the responsibility of the user of this document to comply with all applicable intellectual property laws. Without limiting any rights related to this document, no part of this document may be copied, reproduced or transmitted in any form or by any means (electronic, mechanical, photocopying, recording, or otherwise), or for any purpose, without the expressed permission of Alfa Laval Corporate AB. Alfa Laval Corporate AB will enforce its rights related to this document to the fullest extent of the law, including the seeking of criminal prosecution.