



Instruction Manual

Alfa Laval GJ A2



Covering:
Standard Machines
First published: 2015-07

100017032-EN3 2024-11

Original manual

The information herein is correct at the time of issue but may be subject to change without prior notice.

1. Declaration of Conformity	4
1.1. EU Declaration of Conformity	4.1
1.2. UK Declaration of Conformity	4.2
2. Safety	5
2.1. Important Information	5
2.2. Warning Signs	5
2.3. Safety Precautions	6
3. Introduction	7
3.1. Description	7
3.2. Intended Use	7
3.3. Trademarks	7
3.4. Marking	7
4. Installation	8
4.1. Unpacking/Delivery	8
4.2. Installation	9
4.3. Recycling Information	11
5. Operation	12
5.1. Operation/Control	12
5.2. Trouble Shooting	13
5.3. Cleaning Solution Leakage	14
5.4. Poor Cleaning Performance	15
5.5. Recommended Cleaning	16
6. Maintenance	17
6.1. General Maintenance	17
6.2. General Dismantling Setup	18
6.3. General Dismantling & Installation	19
6.4. Inspection and Service of Components	22
6.5. Reassembly	22
7. Technical Data	25
7.1. Technical Data	25
7.2. Performance Data	26
7.3. Dimensions	27
7.4. Trax Simulation Tool	28
8. Parts List and Service Kits	29
8.1. AL GJ A2 View	29
8.2. Assembly Drawings – 1, 2, 3, 4, 5, 6 & 7	30
8.3. Assembly Drawing – 8	32
8.4. Assembly Drawings – 9, 10, 11 & 12	33
8.5. Assembly Drawing – 13	35
8.6. Assembly Drawing – 14	36
8.7. Assembly Drawing – 15	37
8.8. Parts List	38
8.9. Minor Service Kit	40
8.10. Major Service Kit	41

1. Declarations of Conformity

1.1 EU Declaration of Conformity

The designated company

Alfa Laval Kolding A/S, Albuen 31, DK-6000 Kolding, Denmark, phone no. +45 79 32 22 00

Company name, address and phone number

hereby declare that

Rotary Jet Head

Designation

GJ A2

Type

Serial numbers from NJ-100 to NJ-xxxx

is in conformity with the following directives with amendments:

- Machinery Directive 2006/42/EC

The person authorised to compile the technical file is the signer of this document.

Vice President BU Hygienic Fluid Handling
Head of Product Management

Title

Mikkel Nordkvist

Name

Kolding, Denmark

Place

2024-11-21

Date (YYYY-MM-DD)

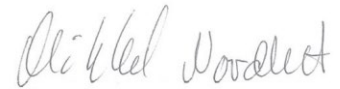

Signature

DoC Revision_02_112024



1.2 UK Declaration of Conformity

The designated company

Alfa Laval Kolding A/S, Albuen 31, DK-6000 Kolding, Denmark, phone no. +45 79 32 22 00

Company name, address and phone number

hereby declare that

Rotary Jet Head

Designation

GJ A2

Type

Serial numbers from NJ-100 to NJ-xxxx

is in conformity with the following directives with amendments:

- Supply of Machinery (Safety) Regulations 2008

Signed on behalf of: Alfa Laval Kolding A/S

Vice President BU Hygienic Fluid Handling
Head of Product Management

Title

Mikkel Nordkvist

Name

Kolding, Denmark

Place

2024-11-21

Date (YYYY-MM-DD)



Signature

DoC Revision_02_112024



*Unsafe practices and other important information are emphasized in this manual.
Warnings are emphasized by means of special signs.
Always read the manual before using the tank cleaning machine!*

2.1 Important Information

WARNING

Indicates that special procedures must be followed to avoid serious personal injury.

CAUTION

Indicates that special procedures must be followed to avoid damage to the tank cleaning machine.

NOTE

Indicates important information to simplify or clarify procedures.

2.2 Warning Signs

General warning:



Dangerous electrical voltage:



Caustic agents:



2 Safety

All warnings in the manual are summarized on this page.

Pay special attention to the instructions below so that severe personal injury and/or damage to the tank cleaning machine are avoided.

2.3 Safety Precautions

Installation:

Always read the technical data thoroughly. (See chapter 7 Technical Data)

Any tank-cleaning machine can develop a static electricity charge while in operation.

If the tank being cleaned contains a combustible liquid or vapor having a risk of ignition or explosion, it is imperative to have the Alfa Laval Gamajet properly grounded using the provided location on the unit.



Operation:

Always read the technical data thoroughly. (See chapter 7 Technical Data)

Necessary precautions must be taken if leakage occurs as this can lead to hazardous situations.



Always handle lye and acid with great care.

When an Alfa Laval Gamajet is operating, there should be covers over every tank opening.



These covers should be sealed well enough to withstand the full force of the jet striking the cover plate.

If the cleaning solution were hot, corrosive, or toxic, a leak would present a serious hazard to any personnel in the immediate vicinity or to any exposed electrical equipment.



Warning: Any tank-cleaning machine can develop a static electricity charge while in operation. If the tank being cleaned contains a combustible liquid or vapor having a risk of ignition or explosion, it is imperative to have the Alfa Laval Gamajet properly grounded using the provided location on the unit.



Maintenance:

Always read the technical data thoroughly. (See chapter 7 Technical Data).

Never service the tank cleaning machine when it is hot.

Always use Alfa Laval genuine spare parts.



Transportation of the tank cleaning machine:

Always drain the tank cleaning machine head and accessories of any liquid

Always use original packaging or similar during transportation

3.1 Description

The Alfa Laval GJ A2 is a fluid-driven (turbine-driven) 360° rotary tank cleaning machine designed to clean the interior surfaces of tanks and vessels. The Alfa Laval GJ A2 is powered entirely by the cleaning solution and it requires no electricity, compressed air or lubricant for operation.

Warning: Under no conditions, whatsoever, should the Alfa Laval GJ A2 ever be immersed in anything, unless you have prior approval from Alfa Laval Gamajet Equipment. Failure to comply with this restriction will void the warranty!!

In order to handle the broadest possible range of applications, the stainless steel Alfa Laval GJ A2 is available with an extensive selection of nozzle sizes, stators (non-rotating turbine), and O-ring materials. The nozzles are available as 2.54mm, 3.2mm, 3.4mm, 3.8mm, 4.2mm 4.7mm and 5.1mm (0.100", 0.125", 0.135", 0.150", 0.165", 0.187", and 0.200"). The Alfa Laval Gamajet wash cycle time can be adjusted for special applications by changing the stator and/or nozzle size. The performance capabilities of these options are detailed in Section 7 – Technical Data.

3.2 Intended Use

It is to be verified by the end-user:

- That the tank cleaning machine is in conformity with respect to tank, vessel or container size in which it will be used.
- That the construction materials (both metallic and non-metallic) are compatible with product, flushing media, cleaning media, temperatures and pressure under the intended use.

3.3 Trademarks

This Instruction Manual is published by Alfa Laval Tank Equipment without any warranty. Improvements and changes to this Instruction Manual may at any time be made by Alfa Laval Tank Equipment without prior notice. Such changes will, however, be incorporated in new editions of this Instruction Manual.

© Alfa Laval Tank Equipment, All rights reserved.

The Alfa Laval logotype is a trademark or the registered trademark of Alfa Laval Corporate AB. "Gamajet" is a trademark or registered trademark of Alfa Laval Tank Equipment. Other products or company names mentioned herein may be the trademarks of their respective owners. Any rights not expressly granted herein are reserved.

3.4 Marking

Alfa Laval Gamajet tank cleaning machines are all marked to allow recognition of machine type, machine name, Serial number and manufacturing address. The marking is placed on the body of the tank cleaning machine.

Alfa Laval Tank Equipment, Coatesville, PA

4 Installation

4.1 Unpacking/Delivery

Step 1

CAUTION

Alfa Laval cannot be held responsible for incorrect unpacking.

Check the delivery for:

1. Complete Cleaning Machine
 2. Delivery note
-

Step 2

Remove any packing materials

Step 3

Inspect the tank cleaning machine for visible transport damage

Inspection!

Read the instructions carefully and pay special attention to the warnings! Always check the tank cleaning machine before operation.

4.2 Installation

Step 1



Always read the technical data thoroughly.
(See chapter 7 Technical Data)

Step 2

Assembly

Every Alfa Laval GJ A2 is operationally tested before shipment and is ready to run after unpacking. **No assembly is required prior to use.** The Alfa Laval GJ A2 has been configured to meet the operating conditions (at the Alfa Laval Gamajet, not at the pump) given to us, e.g. pressure, flow, temperature, cycle time, chemical adders, etc.

Note: Any change to the original operating conditions will affect the Alfa Laval GJ A2 accordingly.

Warning: Do not force Tee & Nozzle Housing, Pos. 39 & 40 to rotate. Doing so may damage the internal components.

Step 3

Inlet Connections

The standard inlet connection for the Alfa Laval GJ A2 is a 1" or 1-1/2" tri-clamp connection. 1-1/2" butt weld, 3/4" FNPT / 1-1/4" camlock plug is available. Appropriate tri-clamp gaskets and clamps are required for the wash fluid. 2" adjustable tank connection is standard.

Step 4

Mounting

Before attaching the supply plumbing to the Alfa Laval GJ A2, make sure the supply line has been adequately flushed. In most applications, the Alfa Laval GJ A2 will be mounted with the inlet connection pointing up; however, the machine will function at any orientation. We do not recommend attaching the machine to a hose while in the inverted or horizontal orientation. This form of mounting is not rigid and, thus, will not maintain the Alfa Laval GJ A2's position should the unit become unbalanced due to clogging of the nozzles.

Warning: When attaching the Alfa Laval GJ A2 onto the supply line, ALWAYS apply the wrench to the Collar (3) at the top/inlet of the unit. Never use a wrench on any other component or its own body to tighten the unit onto the pipe. Doing so risks internally damaging the machine.

Step 5

Entry Openings

The Tee Housing (spray head) section of the Alfa Laval GJ A2 has been designed to fit through a standard 2" Sanitary opening. {Actual ID is 47.5mm (1.87")}

4 Installation

Read the instructions carefully and pay special attention to the warnings! Always check the tank cleaning machine before operation.

Step 6

Vessel Drainage

If it is necessary to clean the floor of a vessel, remember that standing liquid will diminish the effectiveness of the jet by covering any soils underneath.

If the tank is outfitted with a drain, the floor should be pitched toward the drain and the drainage opening should be large enough to eliminate or reduce any liquid buildup or puddling. If gravity alone is insufficient, a scavenger or stripper pump should be connected to the drain to suck out the excess wash fluid. In extreme cases, it may be necessary to use smaller nozzles on the Alfa Laval GJ A2 or even to operate it intermittently to allow time for draining.

If the tank will be evacuated with an external suction source, ensure the suction pump and hose are of sufficient size to keep the liquid level to a minimum.

Step 8

Filters and Strainers

All tank cleaning systems should be equipped with a filter or strainer that will trap solids **0.006" (150 micron, 100 mesh) or larger**, as these will not pass through the Alfa Laval GJ A2. These particles can become caught in one of the internal passages of the machine and cause it to stop turning or reduce its cleaning effectiveness due to a loss of flow. It will then be necessary to disassemble the Alfa Laval GJ A2 and remove the blockage.

In recirculated (closed-loop) cleaning, or, any other application where the cleaning solution may carry abrasive solids in suspension, adequate filtration is a must. These particles can be extremely destructive to the Alfa Laval GJ A2, pumps, valves, and other system components. Filters, properly installed and maintained, will more than pay for themselves with lower overall operating costs in these applications.

Step 9

Capacity of Supply Pump

The Alfa Laval GJ A2 can be used with either a centrifugal or positive displacement (constant volume), PD, style pump. In most cases, if the Alfa Laval GJ A2 is to be used with a centrifugal pump, the Alfa Laval Gamajet should be configured so that the pump will operate close to its best efficiency point. The end user must, therefore, take all of the plumbing, elevation, and Alfa Laval GJ A2 pressure/flow rate requirements into account.

If a PD style pump (i.e. piston pump, plunger pump, or mechanical diaphragm pump, etc.) will supply the wash fluid to the Alfa Laval GJ A2, a different set of rules apply. PD pumps are fixed volume pumps whose flow rate is dependent upon the rotational speed of the pump; the pumps also have a pressure rating which is the **maximum** operating pressure. **Note: Do not confuse the maximum operating pressure of a PD pump with the actual operating pressure, the actual operating pressure is dictated by the fixed flow rate of the pump and the Alfa Laval Gamaje A2 / plumbing system.** If a PD pump is used, the Alfa Laval GJ A2 should be sized to, first, match the flow capability of the pump and, second, not exceed the pump's maximum operating pressure (taking the pressure rating of the plumbing system into account, also).

Warning: For high-pressure applications (over 10bar / 145psig), the pressure of the system must "ramp up" to its operating pressure. If the system experiences a pressure spike or pressure increases at a rate of more than 10bar / 150psi per second, the machine may be damaged and parts will wear out prematurely. Damage resulting from this phenomenon is not covered by the warranty.

Read the instructions carefully and pay special attention to the warnings! Always check the tank cleaning machine before operation.

4.3 Recycling Information

- **Unpacking**

- Packing material consists of wood, plastics, cardboard boxes and in some cases metal straps.
- Wood and cardboard boxes can be reused, recycled or used for energy recovery.
- Plastics should be recycled or burnt at a licensed waste incineration plant.
- Metal straps should be sent for material recycling.

- **Maintenance**

- All metal parts should be sent for material recycling.

- **Scrapping**

- At end of use, the equipment must be recycled according to relevant, local regulations. Beside the equipment itself, any hazardous residues from the process liquid must be considered and dealt with in a proper manner. When in doubt, or in the absence of local regulations, please contact your local Alfa Laval sales company.
-

5 Operation

Read the instruction carefully and pay special attention to the warnings!

5.1 Operation/Control

Step 1



Always read the technical data thoroughly. See chapter 7 Technical Data

CAUTION

Alfa Laval cannot be held responsible for incorrect operation/control.

Step 2



Never touch the tank cleaning machine or the pipelines when pumping hot liquids.

Step 3

Initial Startup

Every Alfa Laval GJ A2 that ships is accompanied by a Birth Certificate. This document indicates how the machine performed in our testing tank before it shipped based on the operating conditions supplied to Alfa Laval Gamajet Equipment. To ensure the longest possible life of the Alfa Laval GJ A2, please verify the operating conditions and, most importantly, the machine's cycle time. The cycle time can be measured by picking a fixed point inside of a vessel as a reference and timing how long it takes the same nozzle to pass back over that point in the vessel. (This, naturally, will not be the exact same spot because the spray pattern is indexing.) To calculate the full cycle time in minutes, multiply this timed value in seconds by 0.75 (3/4).

Pay attention to possible faults
Read the instructions carefully

5.2 Trouble Shooting

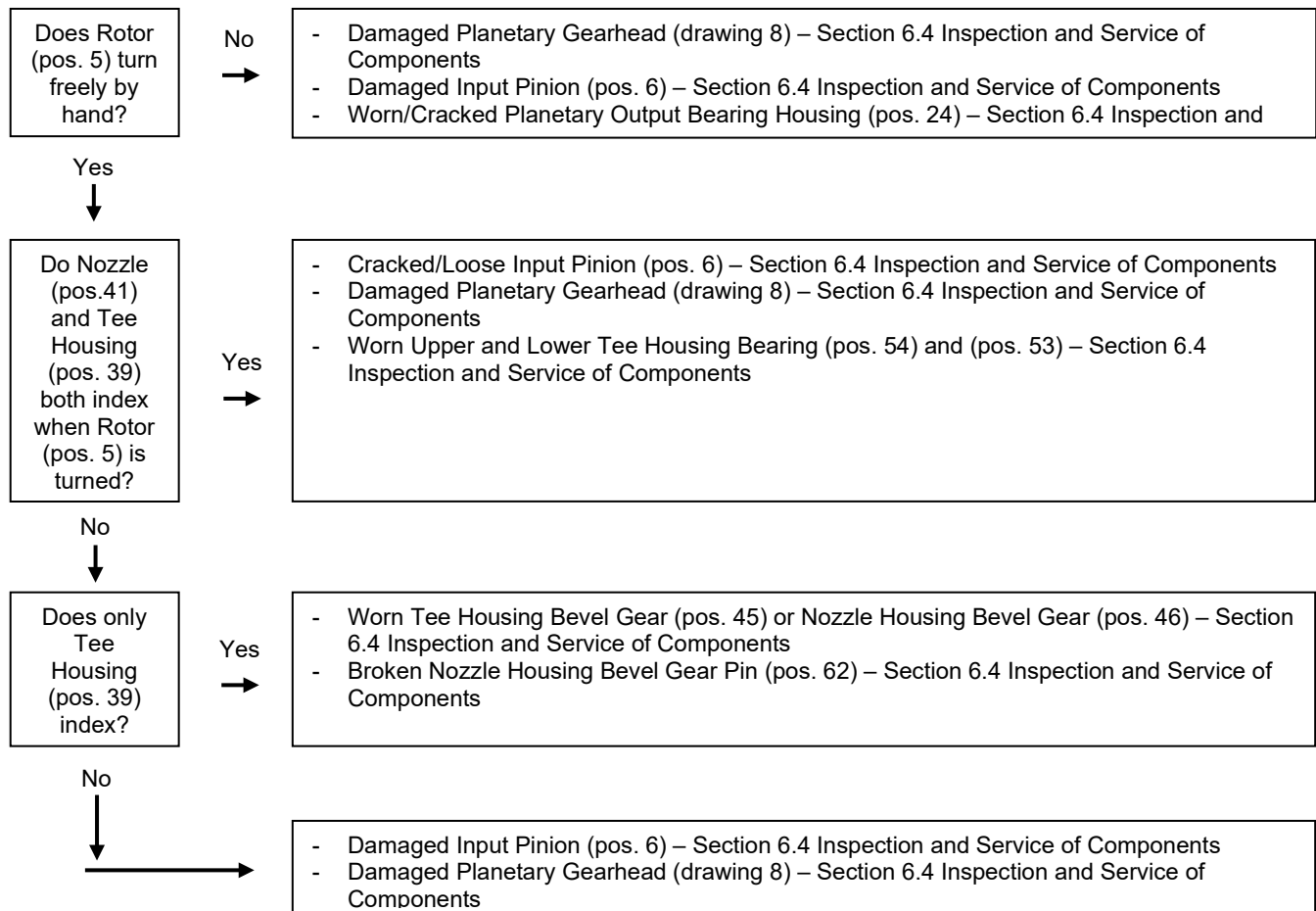

5 Operation

*Pay attention to possible faults
Read the instructions carefully*

Step 1

Long Term Storage

If the Alfa Laval GJ A2 has not been used for over a month, it may be reluctant to initially start because of the natural "set" that occurs with the dynamic parts. To remedy this, loosen the Collar Set Screw (60), remove the Collar (3), and lift out the Stator (4). Using something thin, such as a small hex key or a paper clip, manually rotate the Rotor (5) in the clockwise direction for 20 to 30 revolutions. The (5) should become progressively easier to rotate as you spin it. If so, reassemble the unit and attempt to operate it.

Step 2

Debris Inside

Loosen the Collar Set Screw (60), remove the Collar (3), and lift out the Stator (4). Look for and remove any debris caught in the (4) and the vanes of the Rotor (5). Remove any material wound around the Input Shaft (9). In addition, check for any debris caught in the outlet holes of the Stem (38), the nose of the Tee Housing (39), and the Nozzle Housing (40).

Step 3

Insufficient Flow

The Alfa Laval GJ A2 was configured to meet certain operating conditions outlined at the time of the initial sale, such as flow rate (m³/hr / gpm), pressure (bar / psi), temperature, chemical content of the wash fluid, cycle time, etc. If the Nozzle (42) size is too small and/or the opening at the bottom of the Stator (4) is too large, the Tee Housing (39) will not turn. Look for restrictions in the fluid supply such as a clogged filter, kinked hose, or deposits in the piping.

Step 4

Tight Clearances

A recently overhauled Alfa Laval GJ A2 may fail to operate when first returned to service. If the machine seems otherwise fine, try running it with the Nozzle Housing (40) removed. The reduction in pressure and additional flow will invariably be enough to overcome the extra resistance of new Bearings and Seals. Twenty minutes of operation should loosen the machine to run normally with the (40) reinstalled.

5.3 Cleaning Solution Leakage

- Worn Bearings

Some leakage from the Tee Housing / Stem (39 / 38) and Tee Housing / Nozzle Housing (39 / 40) joints is normal. If the flow rate has noticeably increased, or, the pressure decreased, check the condition of the Tee and Nozzle Housing Bearings, (54) and (53), (48), and (49), respectively. Specifically, examine the condition of the external and internal O-rings.

- Worn Housing

Inspect the internal bores of the Nozzle and Tee Housings (40) and (39) for excessive wear (grooved or scored). Replace any that show distinct grooves.

- Worn Drive Body O-rings

Although some leakage from components positioned inside of the tank is normal, it is not for components that make up the external Planetary Geartrain (drawing 8).

Leakage between the Collar (3) and Cap (2) may indicate worn or damaged Collar O-rings (26) and (27). Remove the (3) and inspect the (26) and (27) for signs of damage or wear.

*Pay attention to possible faults
Read the instructions carefully*

5.4 Poor Cleaning Performance

- **Inadequate Flow and Pressure**

Check the pressure at the Alfa Laval GJ A2 inlet under actual operating conditions. The supply piping and hoses must be large enough to handle the flow rate required for the nozzle size being used to ensure adequate pressure.

Insufficient pressure may also result from line losses when the machine is far from the pump. If this is the case, the line size must be increased accordingly for long runs. Although the Alfa Laval GJ A2 will rotate at low flow rates, effective cleaning may require considerably more flow. Proper mechanical operation (the unit turns) is NOT the same thing as effective cleaning (the soils have been removed)! Contact Alfa Laval Gamajet Equipment if assistance is required.

- **Chemical Concentration and Temperature**

Verify that the cleaning solution is the correct compound and in the concentration needed for the deposit being cleaned. If heating is necessary, also check that the solution is at the proper temperature.

- **Plugged Nozzles**

Inspect the orifices of the Nozzle Housing (40) for any debris.

- **Slow or no Rotation of the Housings**

This will result in partial or erratic washing coverage. Refer to previous sections for more information.

- **Alfa Laval Gamajet 10 Configuration**

Determine if the deposit being cleaned requires greater jet impact or longer jet dwell time (slower rotation) for more thorough scrubbing. Confirm that the Alfa Laval Gamajet nozzle size, turbine, and gearing are correct for the specific application. Refer to the machine's Birth Certificate for specific information regarding its configuration. Contact an Alfa Laval Gamajet Equipment representative if assistance is required.

5 Operation

The Tank Cleaning machine is designed for cleaning in place (CIP). CIP = Cleaning In Place. Study the instructions carefully and pay special attention to the warnings! NaOH = Caustic Soda.
HNO₃ = Nitric acid.

5.5 Recommended Cleaning

Step 1



Always handle lye and acid with great care.

Caustic danger!



Always use rubber gloves!



Always use protective goggles!

Step 2



Never touch the pump or the pipelines when sterilizing.

Danger of burns!

Step 3



Always rinse well with clean water after using a cleaning agent.

Always rinse!

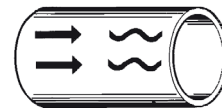

Clean Water

Cleaning agent

NOTE

Cleaning agents must be stored/disposed of in accordance with current regulations/directives.

*Maintain the Tank Cleaning Machine with care. Read the instructions carefully and pay special attention to the warnings!
Always keep Minor spare parts kit in stock.*

6.1 General Maintenance

Step 1



Always read the technical data thoroughly. (see chapter 7 Technical Data)

Step 2

Recommended spare parts:

Order service kits from the service kits list

(See 8.9 Minor Service Kit & 8.10 Major Service Kit)

Ordering spare parts:

Contact your local Alfa Laval Sales company.

6 Maintenance

*Maintain the Tank Cleaning Machine with care. Read the instructions carefully and pay special attention to the warnings!
Always keep Minor spare parts kit in stock.*

6.2 General Dismantling Setup

Step 1

Note

A rigorously implemented preventative maintenance program will significantly reduce repair costs over the life of the Alfa Laval Gamajet. The foundation of such a program is regularly scheduled inspections to discover and replace worn or damaged parts before they can cause the failure of other, more costly, components. The inspection intervals required will depend on the severity of the application, but a complete internal inspection at 100 hours of operation is recommended initially.

Step 2

Storage

The Alfa Laval Gamajet should be washed out with clean water after each use to remove any foreign material or soft substances left in the machine that may harden during storage and cause the Alfa Laval Gamajet to seize or lock up. A clean water rinse through the Alfa Laval Gamajet will also wash out any residues of chemical cleaners or recirculated wash water that could adversely affect the Seals and O-rings during prolonged contact in storage.

Step 3

External Inspection Intervals

Before every shift, the Stator (4) and the orifices of the Nozzle Housing (40). Inspect the (4) by loosening the Collar Set Screw (60) and removing the Collar (3).

Step 4

Internal Inspection Intervals

An interval of 100 hours is recommended initially. If all of the components are found to be in acceptable condition after the first 100 hours, the Alfa Laval GJ A2 may then be inspected and routine preventive maintenance should be performed every 400 to 600 hours of operation, depending on the severity of use. Alfa Laval Gamajet Equipment recommends the following service schedule during the inspections:

Every inspection (about 500 hours):

- Inspect Planetary Geartrain Assembly, Step 8 in Assembly/Disassembly Steps

Every other inspection (about every 1000 hours):

- Replace all Plastic Bearings and Bushings
- Replace all Static and Dynamic Seals
- Replace all O-rings

Every fourth (4th) inspection (about 2000 hours):

- Replace worn Housings and Shaft: 7-212-FT, 7-205-MD and 7-204-MD
-

Step 5

Tips

All the Bearings, Bushings, Seals and O-rings are wear parts. If just one Bearing or Seal is worn or damaged, replace both it and its mate, not just the worn or damaged part.

Read the instructions carefully. The items refer to the parts list and service kits section.

6.3 General Dismantling & Inspection

Step 1

Inlet Collar

Loosen the Collar Set Screw (60) with a 5/64" Hex Key, minimum 2 turns.

Remove the Inlet Collar (3) and Stator (10). If the (3) is tight in coming off of the main body, place the main body in a vise equipped with soft jaw covers. Wrap a towel around the (3) and loosen it with an adjustable wrench.

Warning: Hold or turn on Stem (38). DO NOT hold or turn on Tee Housing (39) or Tee Housing Cap (35). Doing so will damage the Geartrain (drawing 8).

Step 2

Geartrain

Remove the Cap Screws (57) from the Cap (2) part using a 3/32" Hex Key.

Remove the (2) and Body Gasket (32). Alfa Laval Gamajet Equipment recommends replacing all Gaskets after dismantling.

Remove the Collar Small and Large O-rings (26) and (27). Inspect for wear or brittleness and replace as needed. A sharpened brass pick may be helpful in starting to get the (26) and (27) off. Replace with new O-Rings if they show any signs of wear or brittleness.

Loosen the Button Head Screws (51) from the Flow-Thru A2 Stem (50) using a 5/64" Hex Key. It is advisable to use the ball end or shorter end of the Hex Key to loosen and remove the (51).

Holding the Geartrain (drawing 8) and the Stem (drawing 13), remove the Geartrain and Output Shaft (21) from the unit.

Remove the Stem Large Gasket (33) from the assembly and set it aside. Alfa Laval Gamajet Equipment recommends replacing all Gaskets after dismantling.

Step 3

Tee Housing

Using flat jaw pliers or an adjustable wrench, remove the Tee Housing Cap (35) from the Tee housing (39) by holding the (35) still and rotating the (39). **Tip:** The (35) is a Left-Hand Thread.

Unscrew the Tee Housing Assembly (drawing 12) from the Flow-Thru A2 Stem (50). **Tip:** Again, this is a Left-Hand Thread.

Unscrew the Nozzle Housing Cap (41) with a 1/4" slotted screwdriver.

Pull the Nozzle Housing (40; drawing 11) from the nose of the Tee Housing (39).

Unthread and remove the Stem Cap (37; drawing 10). **Tip:** The Stem Cap is a Left-Hand Thread.

Pull the (39) from the Stem (38; drawing 9).

Remove the Tee Housing Bevel Gear (45) and the Tee Housing Upper Bearing (54) by pulling the (45) from the (38; drawing 9). Note how the Bearing has a bevel that fits into the top of the (45).

Check the water outlets on the nose of the (39); they should be free of debris.

Inspect the (45) for worn, damaged or sharp/pointed teeth.

Inspect the Tee Housing Bearings (54) and (53). Clean any deposits from the exterior of them and check their fit in the (39). The external ring may be a tight fit with the inside of the (39). Once installed, however, the body of the Bearings should turn freely. Also, the (56) should be free from damage, compression set, or deterioration.

Clean any deposits from the internal bore of the (39) and examine for excessive wear. Light scoring is acceptable, but the (39) should be replaced if the inside diameter exceeds **23.57mm (0.928")**.

Inspect the (56) for deterioration (compression set or hardening) or damage and replace if necessary.

Inspect the Nozzle Housing Bearings (48) and (49). Clean any deposits from the exterior of the (48) and check their fit in the Nozzle Housing (40). The external ring may be a tight fit with the inside of the (40). Once installed, however, the body of the (48) and (49) should turn freely. Also, the (56) should be free from damage, compression set, or deterioration.

Clean any deposits from inner bore of (40) and examine for excessive wear. Light scoring is acceptable, but the (40) should be replaced if the inside diameter exceeds **17.40mm (0.685")**.

6 Maintenance

Read the instructions carefully. The items refer to the parts list and service kits section.

Step 4

Nozzle Housing

Remove the Snap Ring (47) if needed to remove the Nozzle Housing Bevel Gear (46). Note: There is no need to remove the (46) if it is not damaged.

The Nozzles (42) and Nozzle Housing Plugs (43) have a press fit and should not need to be removed. Inspect the orifice openings in the Nozzle Housing (40) for debris. The inside diameter of each opening must be smooth, round, and free of damage (especially any nicks) for maximum jet impact. In order to maintain the original flow rate and pressure, replace the (40) if the openings are deformed or oversized.

Inspect the (46) for wear such as sharp/pointed or worn teeth. If it needs to be replaced, remove the (47) with a small slotted screwdriver and pry the (46) from the (40).

Step 5

Stem and Stem Cap

Inspect the water outlets of the Stem (38); they should be free of debris.

The Tee Housing Bevel Gear Pin (55) should be firmly pressed into the (38).

Check the inside diameter of the Output Shaft Lower Bearing (36). It should not be greater than **0.334"**. Replace if necessary. Also, ensure that the Output Shaft Extension (44) still has interference with the internal ring of the (36) by passing the (44) through the center of the part. There will still be a slight drag if the ring is still good. If the (36) must be replaced, make sure that the new Bearing is installed with the ring end of the (36) entering the bore of the (38), first.

Inspect the Gearbox O-ring (61) for deterioration (compression set or hardening) or damage and replace if necessary.

Step 6

Output Shaft

If the Output Shaft Extension (44) does not come loose from the Output Shaft (21; drawing 3) on its own, hold the (21) and pull straight down on the (44) until it comes free. If the Dowel Pin (52) that is inserted into the Output Shaft Assembly (drawing 3) is bent, it should be replaced. The (44) and the (52) must be removed in order to further disassemble the Geartrain (drawing 8) further.

Step 7

Geartrain

Tip: *Disassemble the Planetary Geartrain Assembly (drawing 8) over a container or a confined space. There are several small components inside of the Geartrain, which may spill out if you are unfamiliar with its contents.*

Unscrew the Rotor Nut (30) with a 1/4" socket and remove it with the Rotor Gasket (34) from the Input Shaft (9; drawing 6).

Remove the Rotor (5; drawing 7) from the (9; drawing 6). If needed, use a slotted screwdriver for assistance.

Using a 5/64" Hex Key, loosen and remove the two Upper Stem Small Screws (28) that hold down the Gearhead Upper Flange Assembly (10; drawing 1).

Ensuring that the Geartrain Assembly is oriented with the (9; drawing 6) up, carefully remove the (10; drawing 1) by holding down the (9) with one finger and pulling and twisting the (10) from the Geartrain. Applying downward pressure on the (9) ensures that none of the internal gearing is dislodged when the (10) is removed.

Remove the Body Gasket (32).

Carefully remove all of the internal components of the gearhead by resting the tip of the Output Shaft (21; drawing 3) on the table and allowing the Upper Stem (1) and Planetary Ring Gear (12) assembly to slowly drop downward. Holding a finger on the top stage of gears will steady all of the internal components during this process.

After the (1) and (12) have been lowered to the table, take all of the internal gearing, keeping it in one piece, and set it aside. Use the (Stem (38; drawing 9) as a base with the Output Shaft Lower Bearing (36) facing up is recommended.

Unscrew the other two (28) Screws from the Gearhead Lower Flange (24; drawing 2) using a 5/64" Hex Key.

Pull the (24; drawing 2) from the (1).

Remove the (32).

Pull the (12) from the (24). Do not attempt to twist the (12), the Planetary Gearhead Pin (23) prevents this from happening.

Read the instructions carefully. The items refer to the parts list and service kits section.

Step 8

Geartrain Internal Components

Note: The same parts are repeatedly used for all of the stages in the gearhead. It is recommended, but not necessary, to keep the stages in the same order as they are removed.

Carefully separate the different stages of gears by lifting and removing the Planet Gear Carrier (18; drawing 4) of each stage from the lower stage of gears.

When all of the stages are separated, remove the Planetary Gearhead Washer (13) or (29), Planet Gears (15; drawing 5), and Planet Gear Washers (16). As mentioned before, it is recommended to keep each stage of parts together.

Inspect the Washers (29), (20), (13), and (16) for signs of scoring and decrease in thickness. The (29) should not be less than 0.006" thick, and the (13), (16), and (20) should not be less than 0.013" thick. Replace if necessary.

Examine all of the Planet Gears (15) for any worn or broken teeth. Also, verify that all of the Planet Gear Bushings (14) are tight inside of each (15). Their inside diameter should not be greater than 0.095". If they need to be replaced, remove by pressing them out.

Check the components of the Planet Gear Carrier Assemblies (18; drawing 4) and Output Shaft (21; drawing 3). Starting with the Planet Gear Idler Shafts (17). Check for signs of scoring and wear. Examine all of the Planet Gear Carrier Pinions (19) for worn or broken teeth. The worn individual components can be pressed out of the (18) or (21) and replaced with new ones.

However, it is important that all new pieces be fully pressed into and perpendicular to their mates. If you are unable to accomplish this, complete assemblies are available from Alfa Laval Tank Equipment.

Inspect the (21) for signs of scoring and wear. Replace the (21) if wear or scoring has visually decreased the diameter of the (21).

Examine the Planetary Ring Gear (12) for bent or sharp teeth. Replace if required.

Step 9

Input Assembly

Inspect the Input Pinion (6) for hairline cracks on the end face or for worn, damaged, or sharp/pointed teeth. The (6) should be tight to the Input Shaft (9) and the Input Pinion Thrust Washer (11). Press a new (6) back onto the (11) if it has to be replaced due to being cracked or worn.

Check for signs of scoring and wear on (9). Replace as required.

The Dowel Pins (63) should be firmly pressed into the Gearhead Upper Flange (10).

The through holes of the (10) should be clear and free of debris.

Inspect the Body Gasket (32) for permanent set and/or deterioration. Replace if needed.

The Input Carbide Bearing (7) in the Rotor (5) and the Long Input Shaft Carbide Bearing (8) in the (10) should protrude slightly.

In addition, their running surfaces should be smooth and free of chips and cracks.

Step 10

Gearhead Lower Flange Assembly

Inspect the Planetary Ring Gear O-ring (31) for deterioration (hardening/deformation) or damage and replace if necessary.

Check the inside diameter of the Planetary Output Shaft Upper Bushing (22). It should not be greater than **0.380"**. In addition, the distance from top of the flange of the (22) to the top of the Gearhead Lower Flange (24) should not be greater than **0.058"**.

If it needs to be replaced, remove it by pressing it out.

The Pins (63) and (23) should be firmly pressed into the (24).

The Output Shaft Upper Carbide Bearing (25) should be fully pressed into the (24). The (25) will be recessed slightly if properly installed.

Inspect the Body Gasket (32) for permanent set and/or deterioration. Replace if needed.

6 Maintenance

Read the instructions carefully. The items refer to the parts list and service kits section.

6.4 Inspection and Service of Components

Drawings 9, 10

Stem and Stem Cap

Inspect the water outlets of the Stem 7-203; they should be free of debris.

The Pin 7-440 should be firmly pressed into the 7-203.

Check the inside diameter of the 7-124-NJ. It should not be greater than **8.48mm (0.334")**. Replace if necessary. Also, ensure that the bottom Output Shaft 7-212-FT still has interference with the internal ring of the 7-124-NJ by passing the 7-212-FT through the center of the part. There will still be a slight drag if the ring is still good. If the 7-124-NJ must be replaced, make sure that the new bearing is installed with the ring end of the 7-124-NJ entering the bore of the 7-203, first.

Inspect the Stem Cap O-ring 7-751 and Stem O-ring 642-3 for deterioration (compression set or hardening) or damage and replace if necessary. Use a sharp brass pick to aid in removal.

6.5 Reassembly

General Notes

All parts must be cleaned thoroughly before reassembling. Any deposits remaining on the parts can cause difficult disassembly the next time the Alfa Laval Gamajet needs to be serviced. Also, it may cause misalignment of parts and the potential for premature failure.

Unless otherwise stated, apply a dab of a **Teflon-based anti-seize compound** to all threads when reassembling; this will prevent galling of threads and ease any future disassembly.

To ease installation of all O-rings, they should be lubricated prior to reassembly. Lithium-based soap grease is acceptable, for Viton® O-rings; however, a Silicon based lubricant must be used for EPDM O-rings.

Drawings 1 - 8

Geartrain

Push the Planetary Ring Gear (12) over the Gearhead Lower Flange (24), being sure to align the keyway of the (12) with the Planetary Gearhead Pin (23).

Position the Body Gasket (32) over the (24). Align the smallest holes in the gasket over the small through holes for the Upper Stem Small Screws (28).

Place the Upper Stem (1) {8 holes down toward the (24), 6 holes up} over this assembly being sure to align the Dowel Pins (63) with proper holes in the (1).

Pass the Upper Stem Small Screws (28) through the (24; drawing 2) and, using a 5/64" Hex Key, **lightly** tighten them into the (1). Each (28) does nothing more than hold the geartrain assembly together during service and inspections.

Turn the assembly over.

Put the Planetary Output Shaft Washer (20) onto the Output Shaft (21). Insert this assembly into the Planetary Ring Gear (12) and pass the (21) through the center of the (24) until it bottoms out on the Planetary Output Shaft Upper Bushing (22).

Tip: To ease in installation of the internal gearhead components, the Gearhead Assembly (drawing 8) will have to be supported such that the Output Shaft (21) rests at the bottom of the Planetary Ring Gear (12).

Take the Collar (3) and place it on an adequately flat surface, such as a table with the inlet connection facing up. Place the Stem (38) with the Output Shaft Lower Bearing (36) facing up. The internal holes should be centered with each other. Place the Gearhead Lower Flange Assembly (24; drawing 2) and all of the previously installed components on top of this with the (12) facing up.

Drop the (21) through the bottom holes. Now, the (21) will be resting at the bottom of the (24; drawing 2) and the (12).

Using a small shaft, such as a Hex Key, as a guide, drop the Planet Gear Washers (16) and then the Planet Gear Assemblies (15; drawing 5) onto each of the bottom Planet Gear Idler Shafts (17).

Place the bottom Planetary Gearhead Large Washer (13) over each (15).

Drop the Planet Gear Carrier Assembly (18; drawing 4) into the assembly such that the Planet Gear Carrier Pinion (19) teeth engage with all three of the (15)s.

Repeat this procedure until the Washers, Gears, and Carriers have been installed in the (12). As stated previously, it is recommended, but not necessary, that the parts be installed back into the gearhead in their original order.

Read the instructions carefully. The items refer to the parts list and service kits section.

Drawings 1 - 8

Geartrain Continued

Alternate Tip: An alternate procedure is to build up the geartrain outside of the Planetary Ring Gear (12).

Place the Planetary Output Shaft Washer (20) onto the shaft of the Output Shaft Assembly (21; drawing 3). Hold this assembly in the right hand, with thumb, middle and ring fingers, leaving the index finger free. With the left hand, place a Planet Gear Washer (16) on each Planet Gear Idler Shaft (17). Place a Planet Gear Assembly (15; drawing 5) on each (17). Place a Planetary Gearhead Large Washer (13) on top of the (15)s. Place a Planet Gear Carrier Assembly (18; drawing 4) through the (15)s and on top of the 13). Make sure that the (15)s mesh by spinning the (drawing 4).

Repeat this procedure until every (drawing 4), (16), (drawing 5), and (13) are in place on the (21; drawing 3). Place the ring finger of the right hand on top of this geartrain Assembly. **CAREFULLY** insert the tip of the (21; drawing 3) into the (12). The tip of the geartrain assembly should start to protrude from the bottom of the Planetary Output Shaft Upper Bushing (22). Carefully remove the right hand index finger from the geartrain assembly and replace it with the index finger of the left hand.

Twist the (21; drawing 3) in an oscillating manner with the remaining fingers of the right hand and the index finger of the left hand and pushing down with the left hand index finger. The (drawing 5)s will mesh with the Planet Gear Carrier Pinion (19) on the Planet Gear Carrier (18) and the (12) and the assembly will drop into the (12). Be careful to hold the geartrain assembly as this happens, so as the geartrain stays together

Continue this process until all tiers of the (drawing 5)s are in place. As stated previously, it is recommended, that the parts be installed back into the gearhead in their original order.

Place the Planetary Gearhead Top Washer (29) onto the top layer of Planet Gears (15; drawing 5).

Position the Body Gasket (32) over the Upper Stem (1), aligning the smallest holes with the small threaded holes for the Upper Stem Small Screws (28).

Install the Input Shaft Assembly (9; drawing 6) into the center of the assembly, such that the Input Pinion (6) engages with the top (15)s. Test the geartrain alignment by twisting the (9) in an oscillating manner. The Output Shaft Assembly (21; drawing 3) should spin at a very slow speed as compared to the (9).

Position the Gearhead Upper Flange Assembly (10; drawing 1) over the (9). Align the holes in the (10) with the holes in the (1). Pass the second set of (28)s through the (10) and, using a 5/64" Hex Key, **lightly** tighten the (28)s into the (1).

Place the Rotor (5; drawing 7) {Carbide Bearing (7) down} over the (9).

Using a 1/4" socket, tighten the Rotor Nut (30) and Rotor Gasket (34) onto the (9).

Rotate the (5) 10-20 times in a clockwise manner to verify there are no catches or snags within the geartrain. If there are any catches or drag within the gearhead, stop immediately.

Replace the Dowel Pin (52) into the (21) and then place the Output Shaft Extension (44) over the end of the (21). Align the slot on the (44) to the (52) through the (21) and press the two shafts together fully.

Drawing 14

Cap

Position the Body Gasket (32) over the Gearhead Upper Flange (10), aligning the smallest holes of the (32) with the holes for Upper Stem Small Screws (28).

Place the Cap (2) on the geartrain assembly, aligning the Dowel Pins (63) and holes.

Using a 3/32" Hex Key, screw the Cap Screws (57) into the Upper Stem (1). Tighten in a star pattern.

Drawing 11

Nozzle Housing

Install Nozzle Housing Bevel Gear Pin (62) into the hole in the Nozzle Housing (40).

Position the Nozzle Housing Bevel Gear (46) so the drilled hole lines up with the (62) and install (46) onto the (40). The lower face of the (46) should be flush with the mating surface of the (40) with no gaps.

Install the Snap Ring (47) on the (40) using a small flat screw driver.

6 Maintenance

Read the instructions carefully. The items refer to the parts list and service kits section.

Drawing 12

Tee Housing

Slide the Tee Housing Bevel Gear (45) over the end of the Stem (38; drawing 9). Align the hole in the (45) with the Dowel Pin (55) in the (38).

Place the Tee Housing Upper Bearing (54) onto the (38). Lubrication of the internal O-ring is recommended. The chamfer on the edge of (54) should fit into the chamfer on the body of the (45).

Push the Tee Housing (39) over it until it is flush and fully seated. If a new (45) has been installed, there will be a slight resistance as the external ring of this part is inserted into the (39).

Place the Tee Housing Lower Bearing (53) over the (38) and push it down fully into the space between the (38) and (39). Lubrication of the internal O-ring is recommended.

Thread the Stem Cap (37; drawing 10) onto the end of the (38). This is a Left-Hand Thread.

Push the Nozzle Housing Lower Bearing (48) onto the (39). Lubrication of the internal O-ring is recommended. To prevent the internal O-ring from being cut by the windows in the (39), twist the (48) as it slides over the (39).

Push the Nozzle Housing (40; drawing 11) onto the nose of the (39). If a new set of Nozzle Housing Bearings (48) and (49) has been installed, there will be a slight resistance as the external ring of the (48) and (49) is inserted into the (40).

Rotate the Tee Housing Assembly slightly to mesh the Bevel Gears (45) and (46). Failure to ensure that the Bevel Gears have properly mated could damage them.

Place the (49) onto the nose of the (39), push it into the space between the (39) and (40). Lubrication of the internal O-ring is recommended.

Thread the Nozzle Housing Cover Plate (41) into the nose of the (39) using a ¼" slotted screwdriver.

Drawings 13

Tee Housing Cap

Screw the Stem (38) onto the Flow-Thru A2 Stem (50). This is a Left-Hand Thread.

Place the Tee Housing Cap (35) into the Tee Housing (39). Rotate the (39) until the (35) is fully engaged. Again, this is a Left-Hand Thread. Hand Tighten to secure in place.

Drawing 14

Stem and Geartrain

Align the Stem Large Gasket (33) with the through holes in the Flow-Thru A2 Stem (50) part.

Insert the geartrain (drawing 8) into the (50).

The geartrain may need to be rotated until the flat section of the Output Shaft Extension (44) aligns with the slot in the Tee Housing Cap (35). There will be a slight resistance as it passes through the top Seal. The shaft is fully installed when the flange at the end comes to rest in the (35).

Screw the Button Head Screws (51), using a 5/64" Hex Key, into the (50). Hand-tighten in a star pattern.

Using a small screwdriver or hex key, rotate the Rotor (5) clockwise 10-20 rotations to verify there are no catches or snags inside the geartrain.

Drawing 15

Stator and Collar

Place the Stator (4) into the Cap (2).

Thread the Collar (3) onto the (2) until it stops and captures the (4).

Tighten the Collar Set Screw (60) using a 5/64" Hex Key.

*It is important to observe the technical data during installation, operation and maintenance.
Inform personnel about the technical data.*

7.1 Technical Data

The Alfa Laval GJ A2 Tank Cleaning Machine is a highly efficient machine at a range of pressures and flows. The instruction manual is part of the delivery. Read the instructions carefully.

TECHNICAL DATA

Lubricant Self-lubricating
Max. throw length 4 - 5 m (12 - 14 ft.)

Pressure

Working pressure 2.75 - 14 bar (40 - 200 PSI)
Recommended pressure 4 - 10 bar (50 - 150 PSI)

Cleaning Pattern

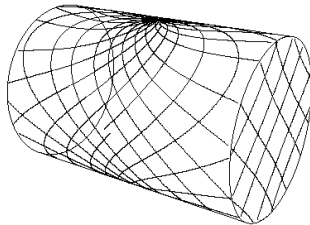

First Cycle

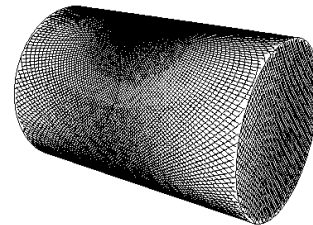

Full Pattern

The above drawings show the cleaning pattern achieved on a cylindrical horizontal vessel. The difference between the first cycle and the full pattern represents the number of additional cycles available to increase the density of the cleaning.

Certificate

2.1 Material Certificate

PHYSICAL DATA

Materials

316L, PPS, PTFE, FKM (EPDM and FKM available).

Temperature

Max. working temperature 95°C (203°F)
Max. ambient temperature 140°C (284°F)

Weight 2.26 kg (5 lbs.)

Surface Finish 0.5 µm (20 Ra)

Connections

Standard thread 1 ½" Tri-Clover
Available option ¾" NPT, 1" Tri-Clover, 1 ½" Tube

Options

Electronic rotation sensor to verify 3D coverage.

Caution

Do not use for gas evacuation or air dispersion.

7 Technical Data

It is important to observe the technical data during installation, operation and maintenance.
Inform personnel about the technical data.

7.2 Performance Data

Flow Rate (2 nozzle)

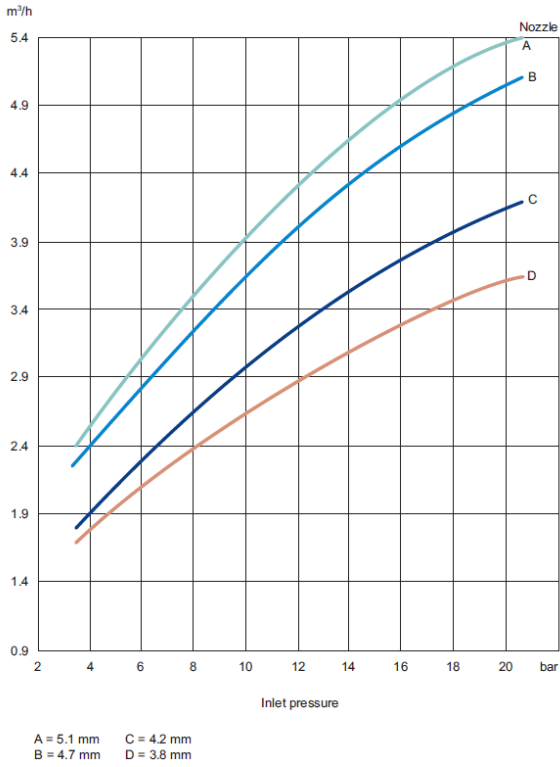

Flow Rate (4 nozzle)

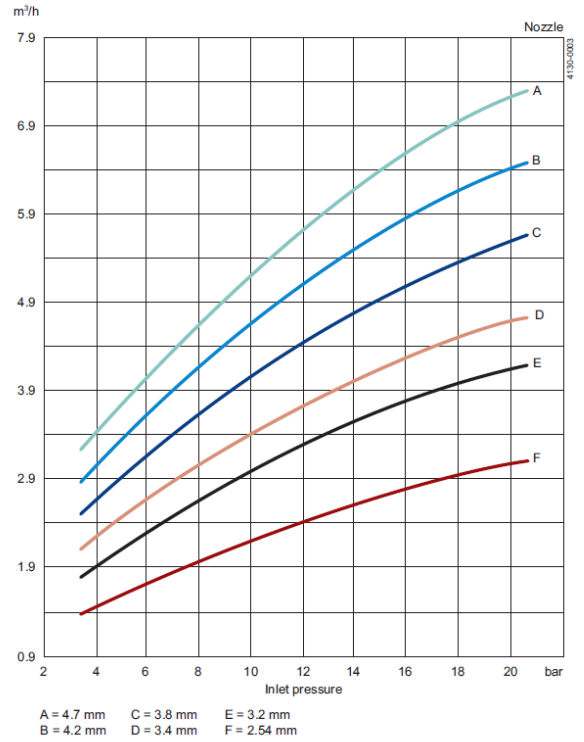

Impact Throw Length (2 nozzle)

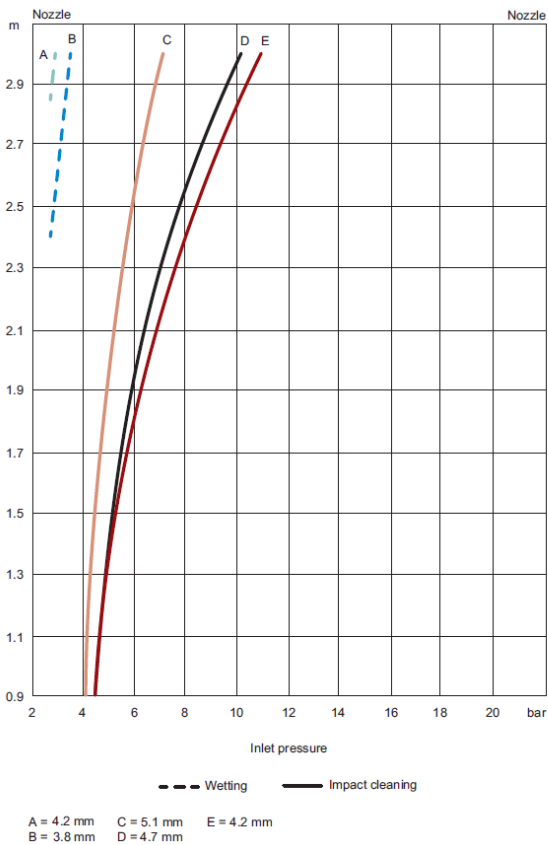

Impact Throw Length (4 nozzle)

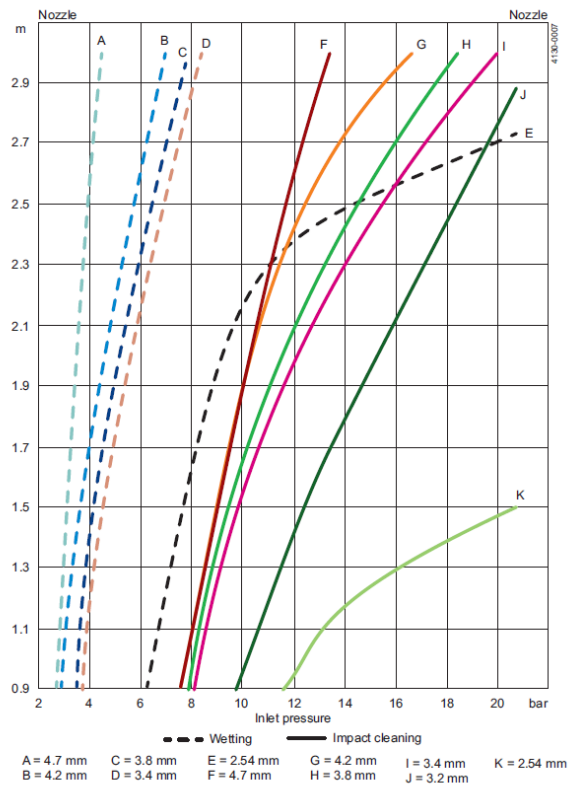

Cleaning Time

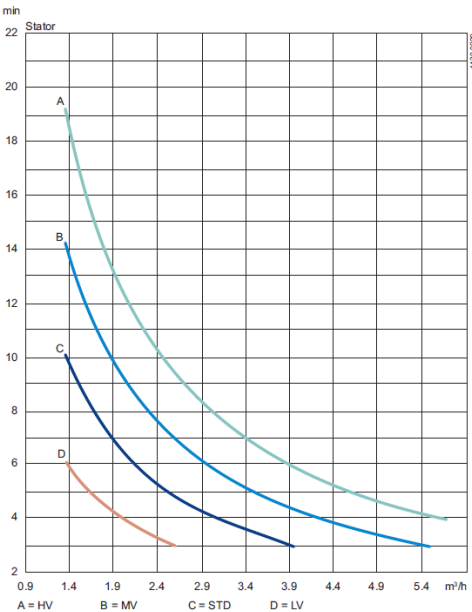

It is important to observe the technical data during installation, operation and maintenance. Inform personnel about the technical data.

7.3 Dimensions

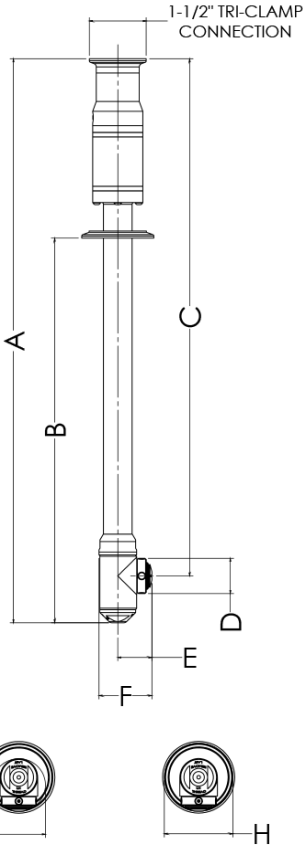

Dimensions

	A	B	C	D	E	F	G	H
mm	503	343	431	31	30	47	47	61
in	19.8	13.5	18.1	1.2	1.2	1.9	1.9	2.4

7 Technical Data

*It is important to observe the technical data during installation, operation and maintenance.
Inform personnel about the technical data.*

7.4 Trax Simulation Tool

Standard Design

The choice of nozzle diameters can optimize jet impact length and flow rate at the desired pressure. As standard documentation, the Alfa Laval GJ A2 can be supplied with a "Declaration of Conformity" for material specifications.

TRAX Simulation Tool

TRAX is a unique software that simulates how the Alfa Laval GJ A2 performs in a specific tank or vessel. The simulation gives information on wetting intensity, pattern mesh width and cleaning jet velocity. This information is used to determine the best location of the tank cleaning device and the correct combination of flow, time, and pressure to implement.

A TRAX demo containing different cleaning simulations covering a variety of applications can be used as a reference and documentation for tank cleaning applications. The TRAX demo is free and available upon request.

Wetting Intensity

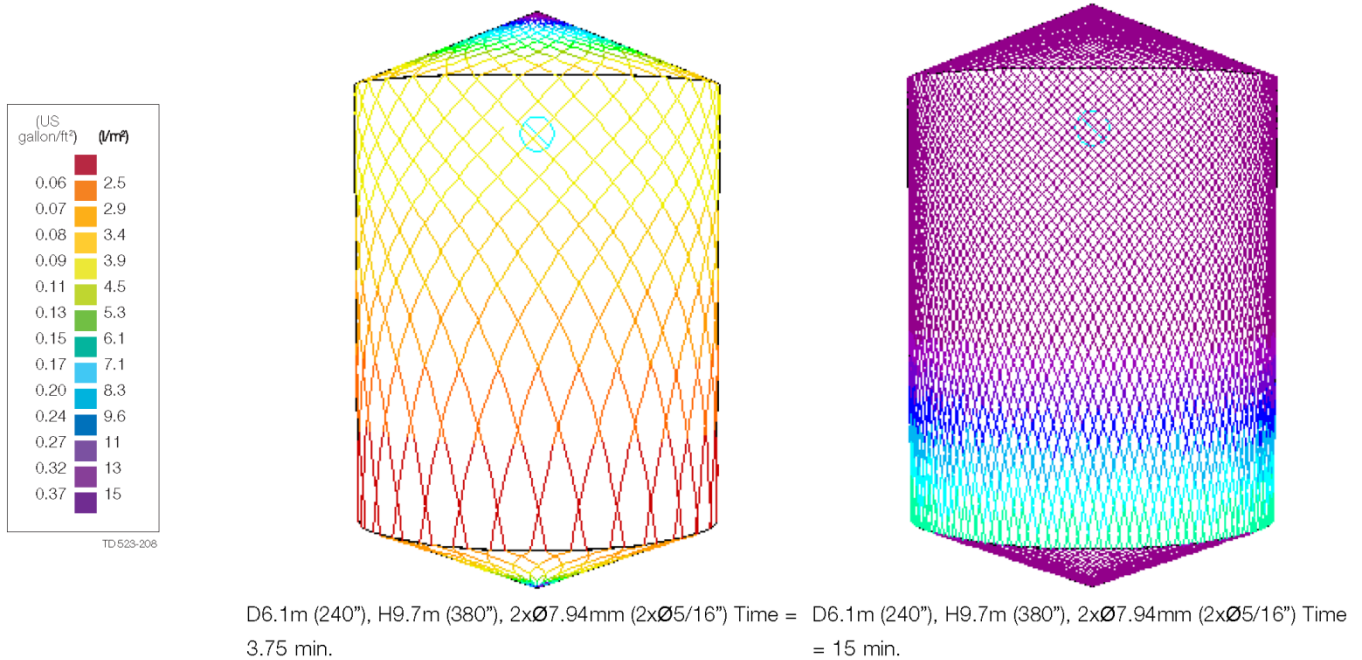

The Drawing shows Alfa Laval GJ A2 Tank Cleaning Machine

8.1 AL GJ A2 View

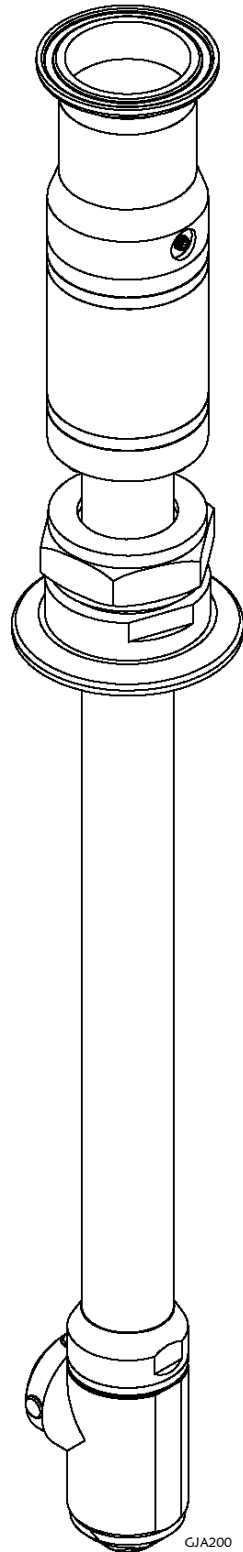

GJA200

8 Parts List and Service Kits

The Drawing shows Alfa Laval GJ A2 Tank Cleaning Machine

8.2 Assembly Drawings – 1, 2, 3, 4, 5, 6 & 7

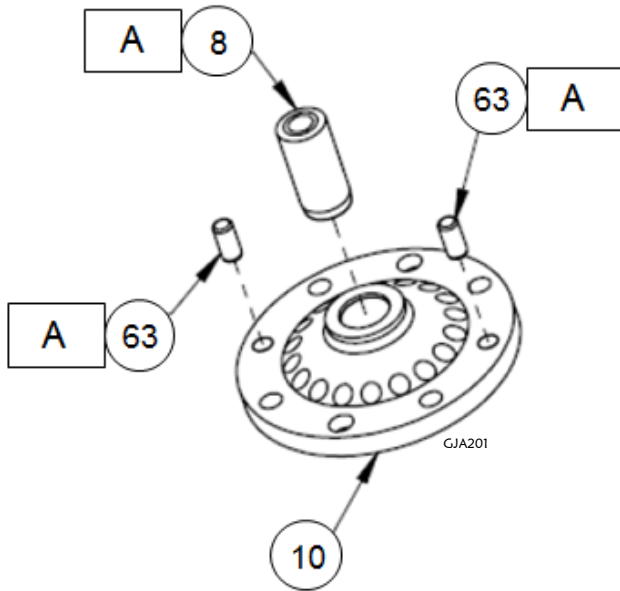

Drawing 1 – Gearhead Upper Flange

A: Press Fit

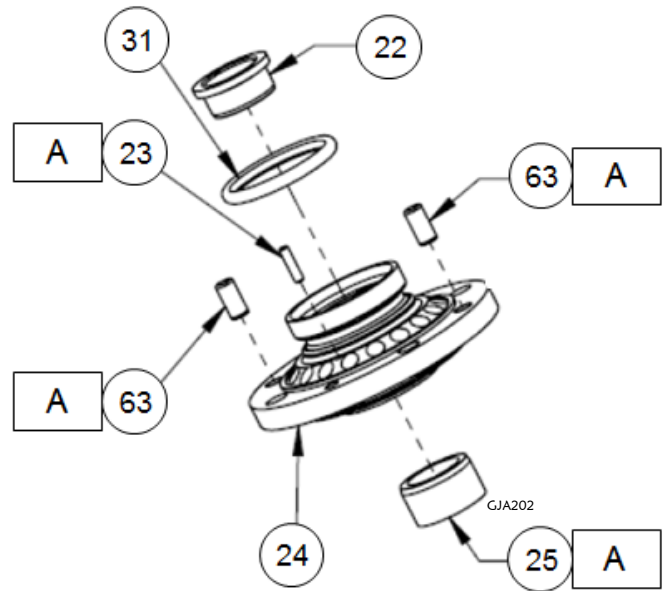

Drawing 2 – Gearhead Lower Flange

A: Press Fit

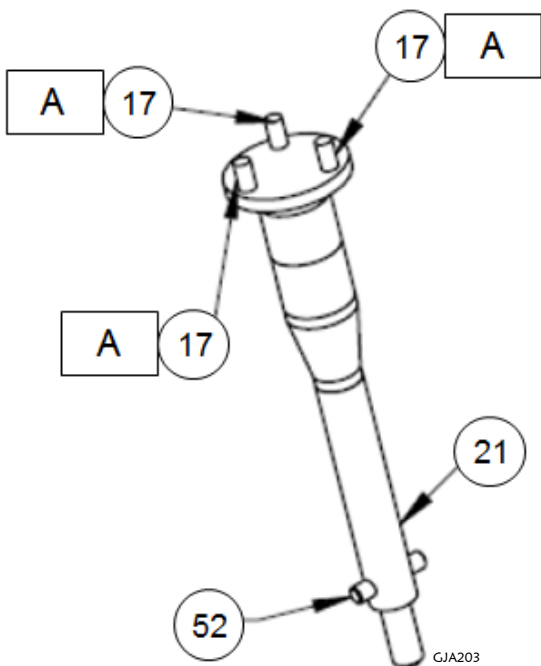

Drawing 3 – Output Shaft

A: Press Fit

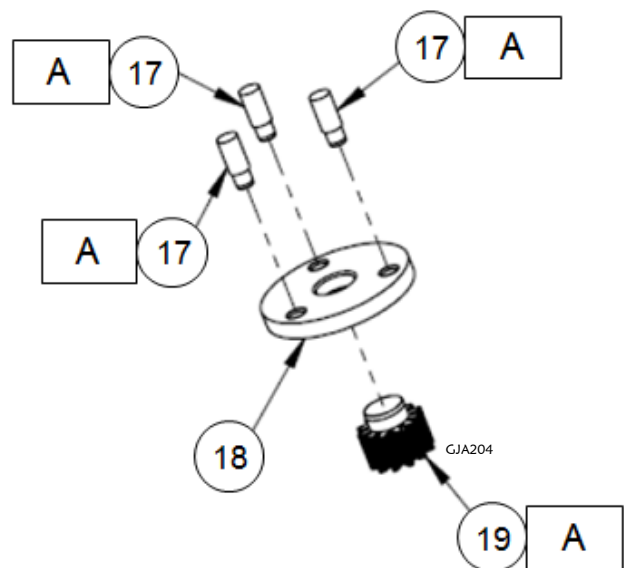

Drawing 4 – Planet Gear Carrier

A: Typical

The Drawing shows Alfa Laval GJ A2 Tank Cleaning Machine

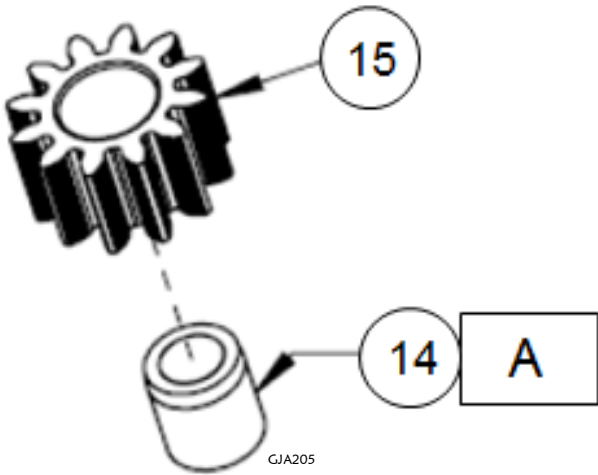

Drawing 5 – Planet Gear

A: Press Fit

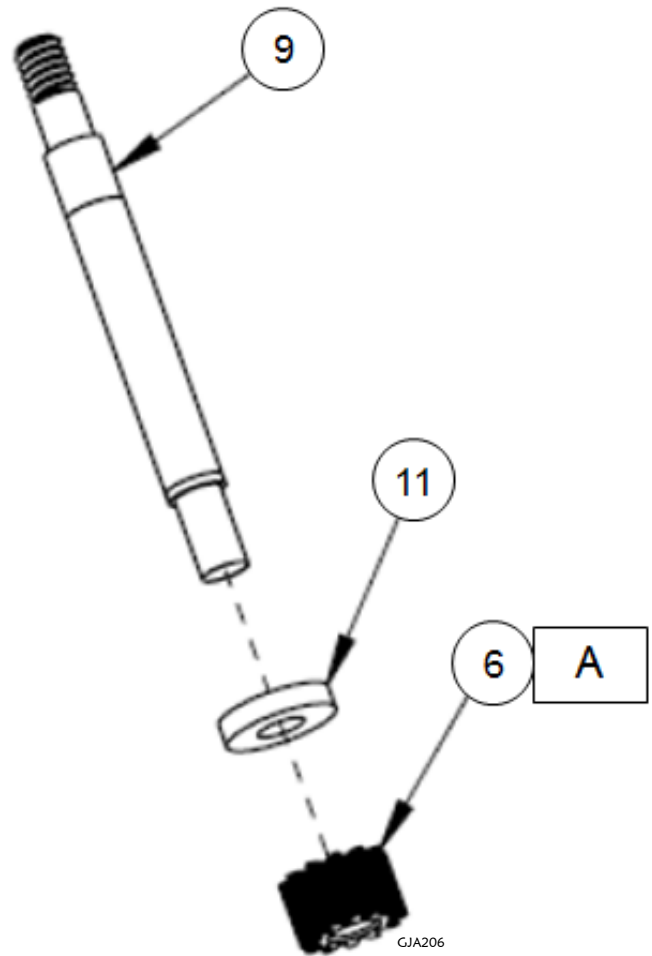

Drawing 6 – Input Shaft

A: Press Fit

Note: The (6) must be completely perpendicular to the (9) or it will not press on correctly and damage the (6) or (9).

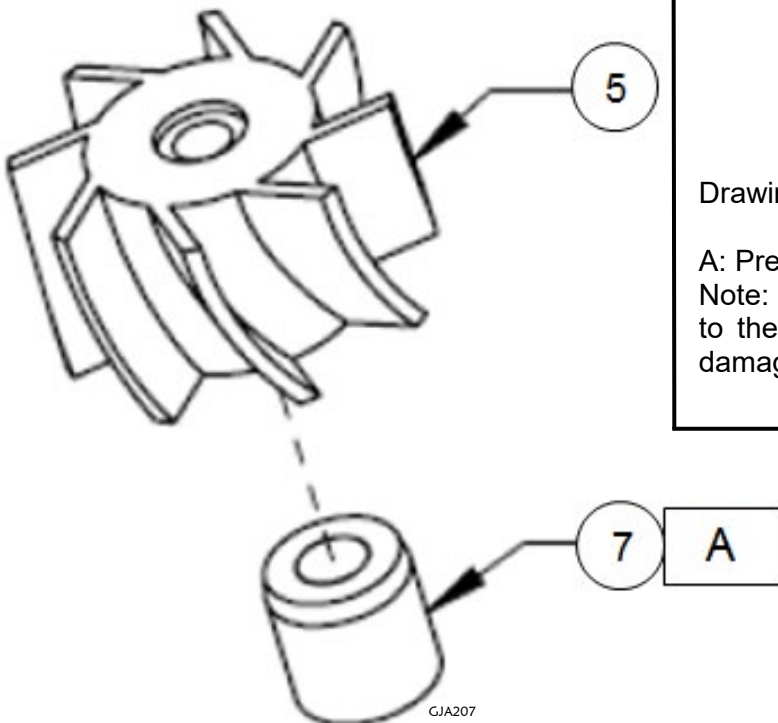

Drawing 7 – Rotor

A: Press Fit

8 Parts List and Service Kits

The Drawing shows Alfa Laval GJ A2 Tank Cleaning Machine

8.3 Assembly Drawing – 8

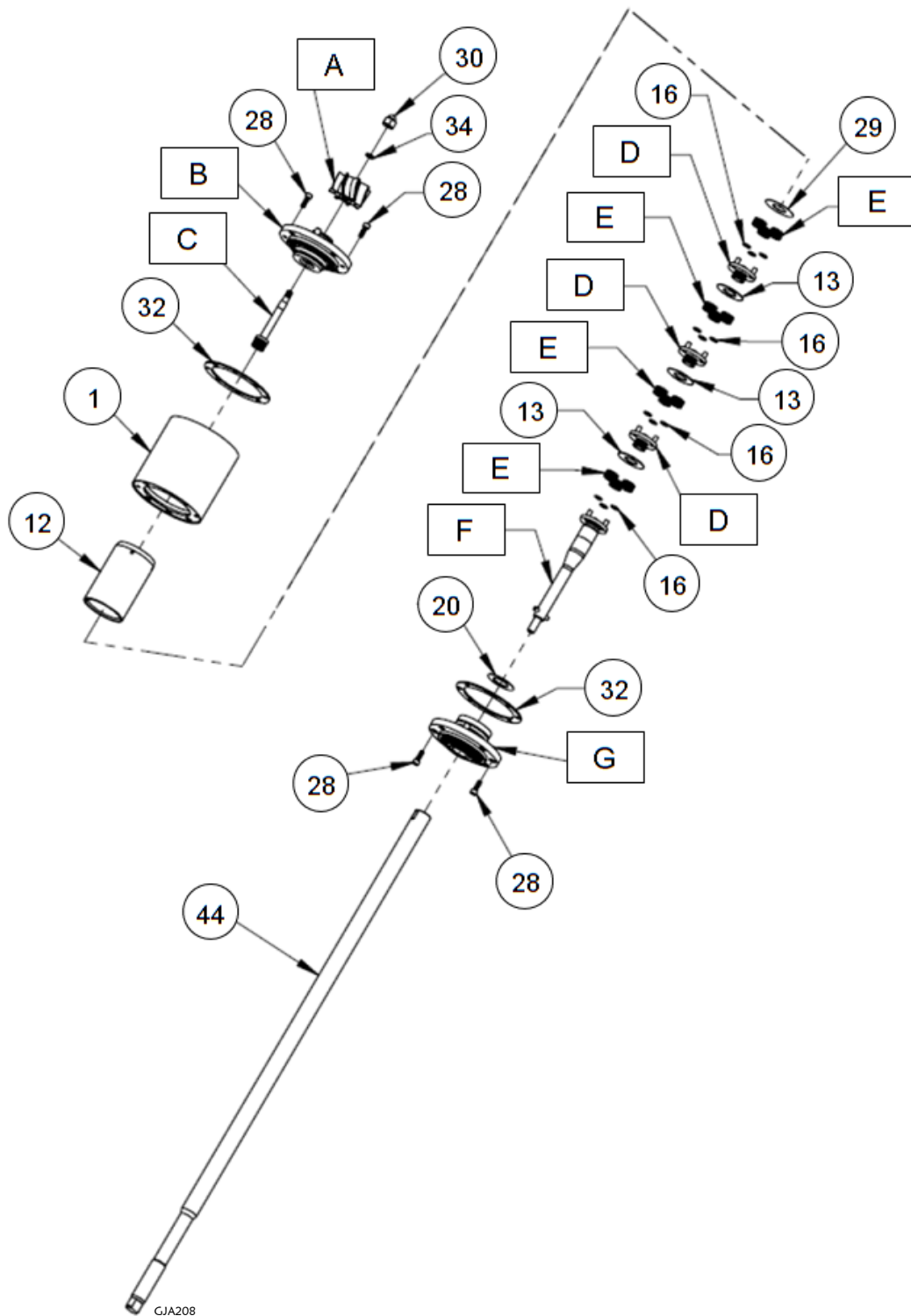

Drawing 8 – Planetary Geartrain

- | | |
|--------------|--------------|
| A: Drawing 7 | E: Drawing 5 |
| B: Drawing 1 | F: Drawing 3 |
| C: Drawing 6 | G: Drawing 2 |
| D: Drawing 4 | |

The Drawing shows Alfa Laval GJ A2 Tank Cleaning Machine

8.4 Assembly Drawings – 9, 11 & 12

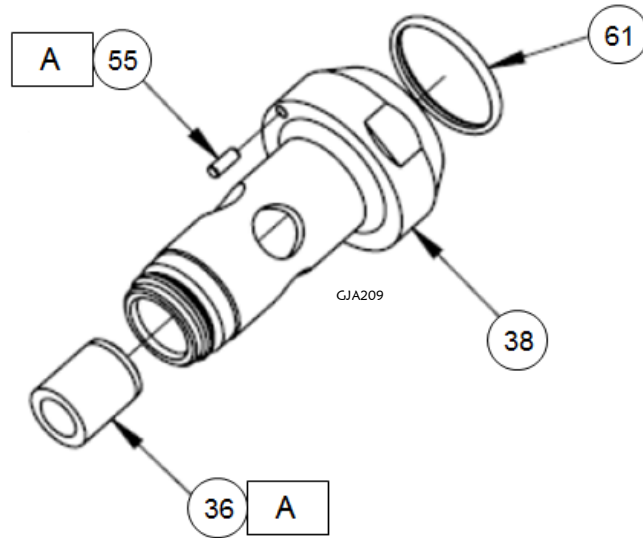

Drawing 9 – Stem

A: Press Fit

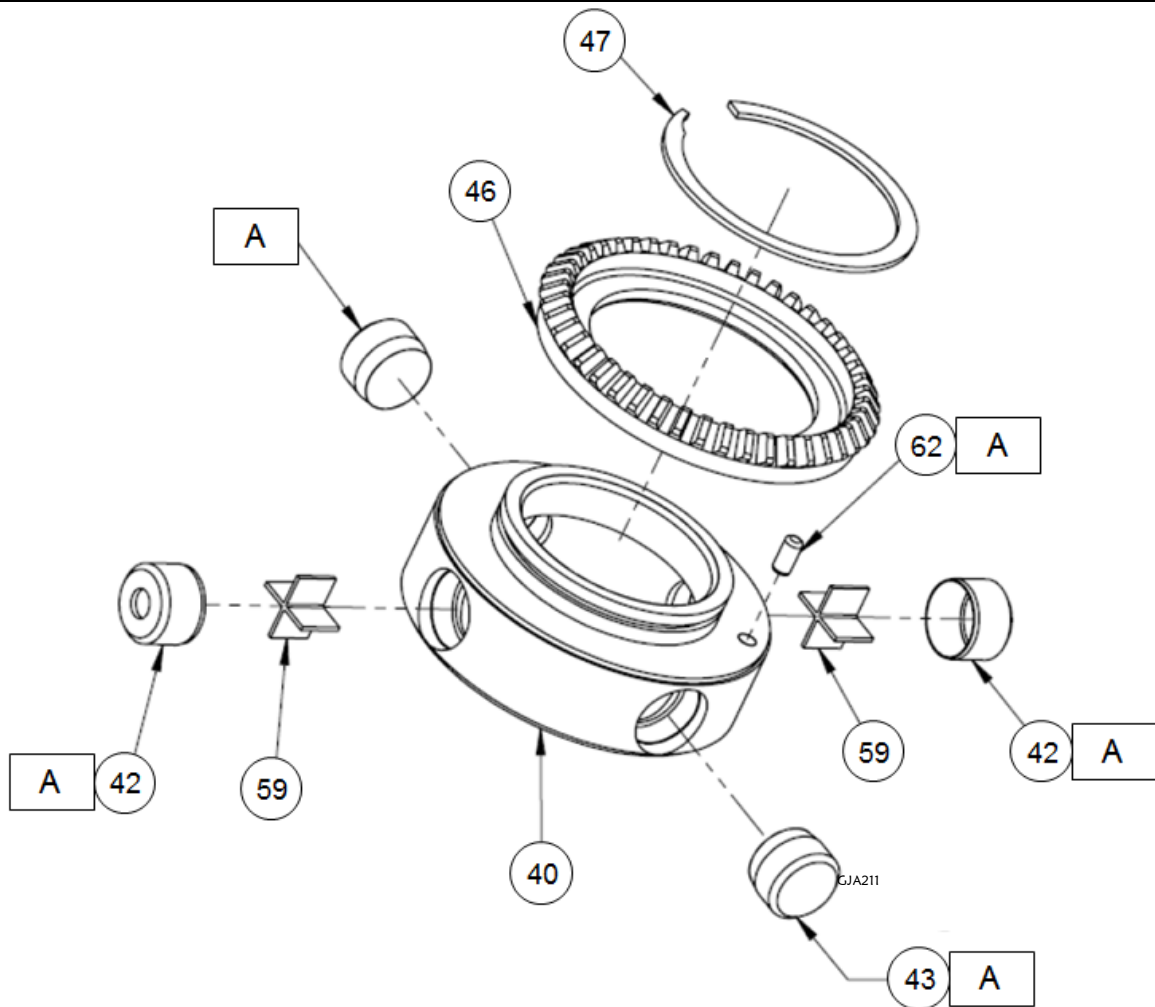

Drawing 11 – Nozzle Housing

A: Press Fit

8 Parts List and Service Kits

The Drawing shows Alfa Laval GJ A2 Tank Cleaning Machine

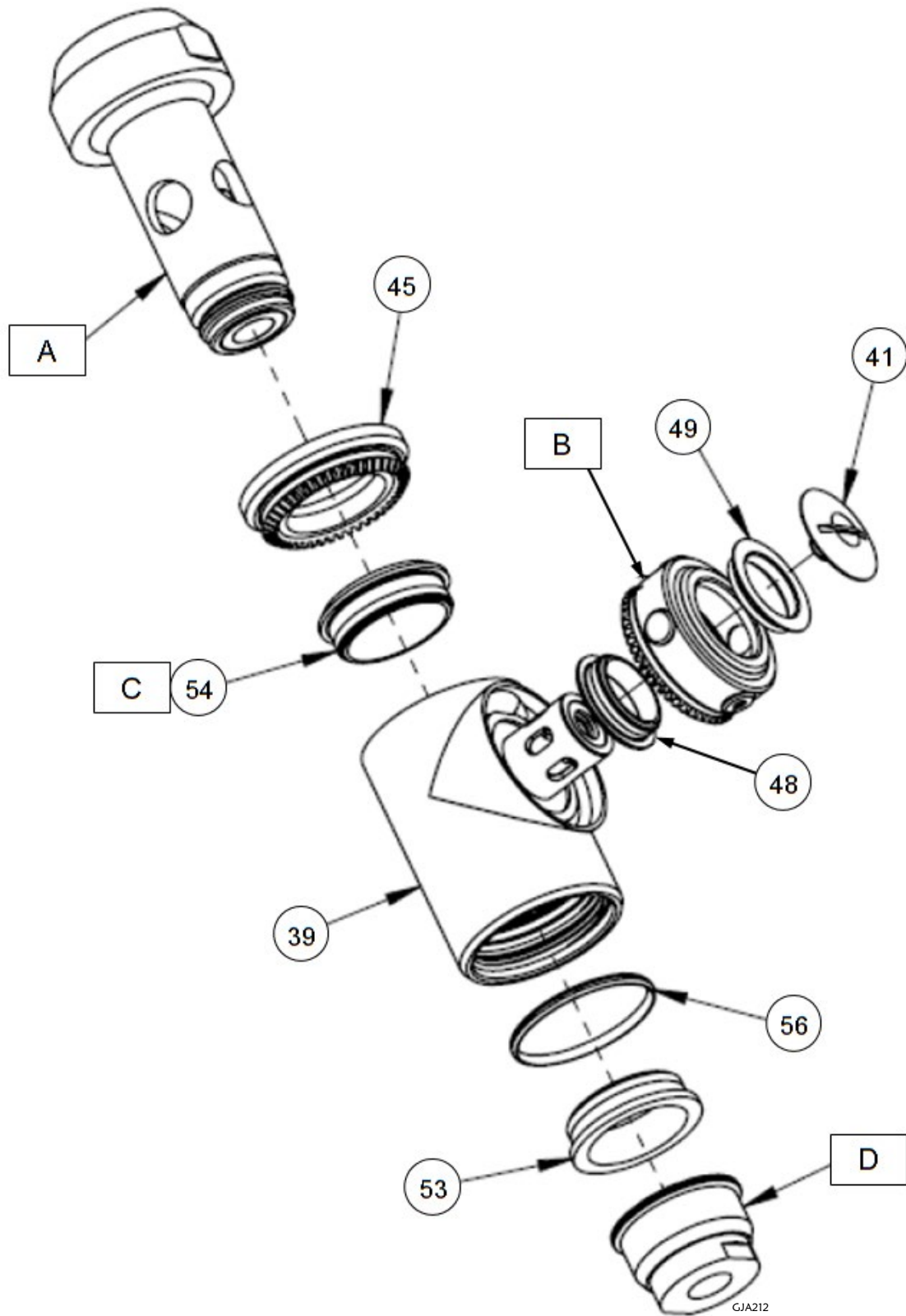

Drawing 12 – Nozzle Housing

A: Drawing 9

B: Drawing 11

C: Large Chamfer on Flange

D: Drawing 10

The Drawing shows Alfa Laval GJ A2 Tank Cleaning Machine

8.5 Assembly Drawing – 13

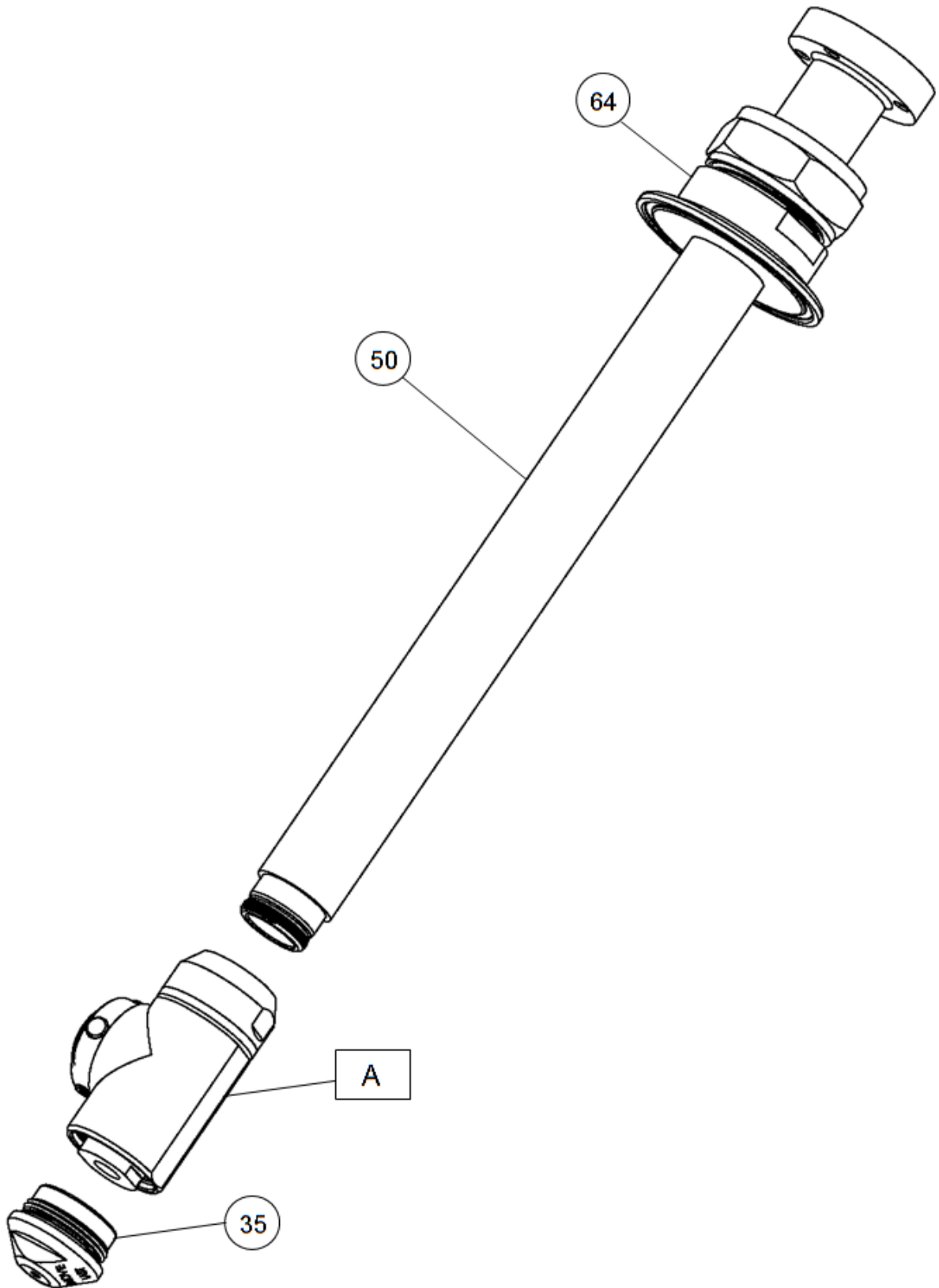

Drawing 13 – Tee Housing Cap

A: Drawing 12

8 Parts List and Service Kits

The Drawing shows Alfa Laval GJ A2 Tank Cleaning Machine

8.6 Assembly Drawing – 14

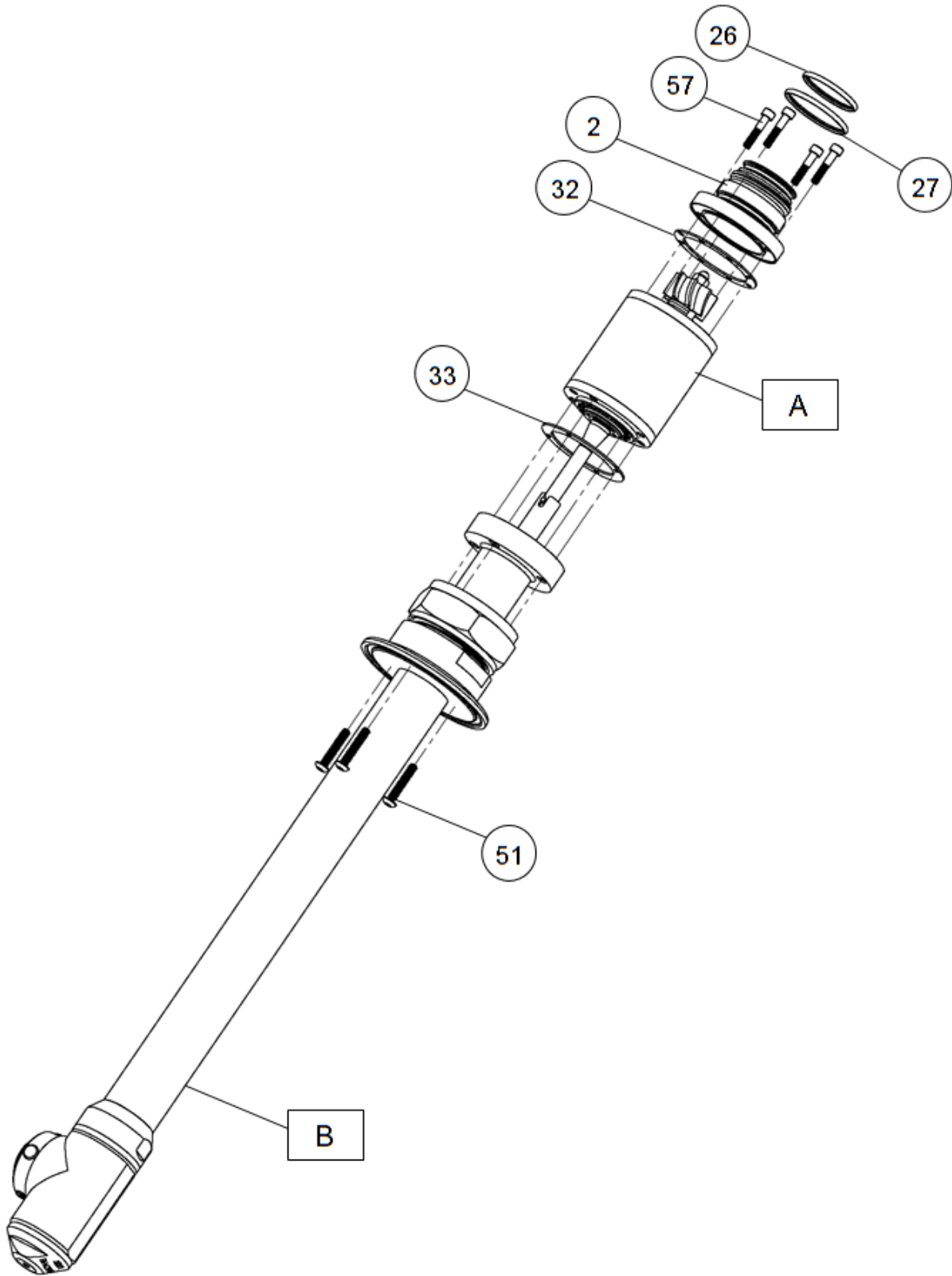

Drawing 14 – Stem and Cap

A: Drawing 8
B: Drawing 13

The Drawing shows Alfa Laval GJ A2 Tank Cleaning Machine

8.7 Assembly Drawing – 15

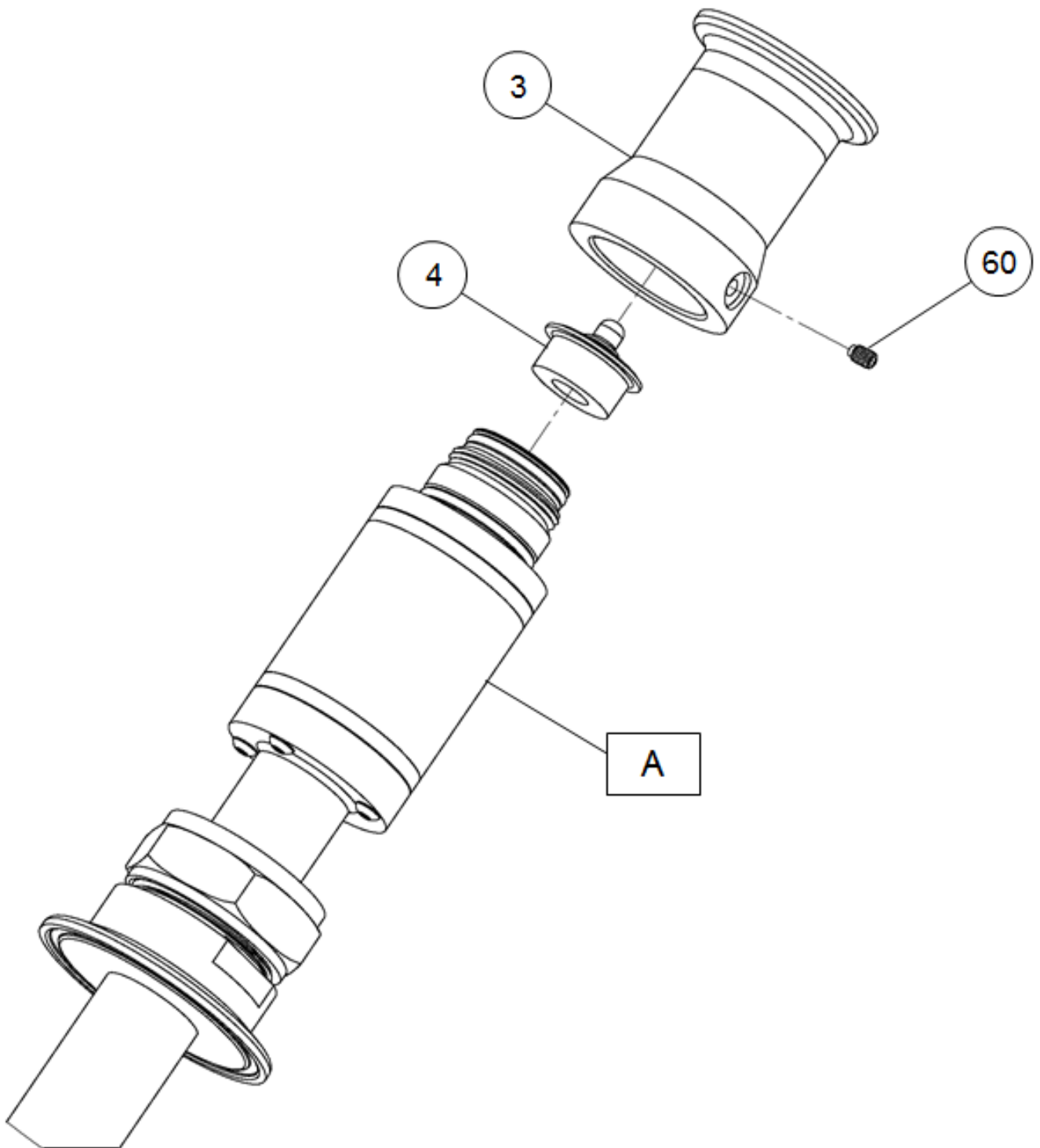

Drawing 15 – Completed Assembly

A: Drawing 14

8 Parts List and Service Kits

8.8 Parts List

Pos.	AL No.	Gamajet No.	Description	No.
1	9614620002	6-101-3A	Upper Stem	1
2	9614620202	6-102-3A	Cap	1
3	9614621205	6-108-TC	Collar	1
4.1	9614621301	6-109-HV	Stator – HV	1
4.2	9614621303	6-109-MV	Stator – MV	1
4.3	9614621304	6-109-STD	Stator – STD	1
4.4	9614621302	6-109-LV	Stator – LV	1
5	9614621401	6-110	Rotor	1
6	9614621601	6-112	Input Pinion	1
7	9614621701	6-113	Input Carbide Bearing	1
8	9614621801	6-114	Long Input Shaft Carbide Bearing	1
9	9614622801	6-122	Input Shaft	1
10	9614623101	6-123-3A	Gearhead Upper Flange	1
11	9614623201	6-124	Input Pinion Thrust Washer	1
12	9614623301	6-125	Planetary Ring Gear	1
13	9614623401	6-126	Planetary Gearhead Large Washer	3
14	9614623601	6-127-3A	Planet Gear Bushing	12
15	9614623701	6-128	Planet Gear	12
16	9614623801	6-129	Planet Gear Washer	12
17	9614623901	6-130	Planet Gear Idler Shaft	12
18	9614624901	6-137	Planet Gear Carrier	3
19	9614625001	6-138	Planet Gear Carrier Pinion	3
20	9614625101	6-140	Planetary Output Shaft Wahser	1
21	9614625301	6-141-FT	Output Shaft	1
22	9614625501	6-142-3A	Planetary Output Shaft Upper Bearing	1
23	9614625601	6-143	Planetary Gearhead Pin	1
24	9614625801	6-144-3A	Gearhead Lower Flange	1
25	9614625901	6-145	Output Shaft Upper Carbide Bearing	1
26.1	9614626901	6-153-E	Collar Small O-ring – EPDM	1
26.2	9614626902	6-153-V	Collar Small O-ring – Viton	1
26.3	9614626903	6-153-Z	Collar Small O-ring – Kalrez	1
27.1	9614627001	6-154-E	Collar Large O-ring – EPDM	1
27.2	9614627002	6-154-V	Collar Large O-ring – Viton	1
27.3	9614627003	6-154-Z	Collar Large O-ring – Kalrez	1
28	9614628101	6-168	Upper Stem Small Screw	4
29	9614628201	6-170	Planetary Gearhead Top Washer	1
30	9614628401	6-172	Rotor Nut	1
31	9614628701	6-175	Planetary Ring Gear O-ring	1
32.1	9614629401	6-186-E	Body Gasket – EPDM	3
32.2	9614629403	6-186-V	Body Gasket – Viton	3
32.3	9614629402	6-186-K	Body Gasket – Kalrez	3
33.1	9614629501	6-187-E	Stem Large Gasket – EPDM	1
33.2	9614629503	6-187-V	Stem Large Gasket – Viton	1
33.3	9614629502	6-187-K	Stem Large Gasket – Kalrez	1
34.1	9614629701	6-189-E	Rotor Gasket – EPDM	1
34.2	9614629703	6-189-V	Rotor Gasket – Viton	1
34.3	9614629702	6-189-K	Rotor Gasket – Kalrez	1
35	9614632701	7-114-NJ	Tee Housing Cap	1
36	9614633001	7-124-NJ	Output Shaft Lower Bearing	1
37	9614633401	7-130	Stem Cap	1
38	9614691901	7-203	Stem	1
39	9614692101	7-204-MD	Tee Housing	1
40	9614692301	7-205-MD	Nozzle Housing	1
41	9614692501	7-206-MD	Nozzle Housing Cap	1
42.1	9614692701	7-207-MD	Nozzle – 0.100"	2
42.2	9614692702	7-207-MD	Nozzle – 0.125"	4
42.3	9614692703	7-207-MD	Nozzle – 0.135"	2,4
42.4	9614692704	7-207-MD	Nozzle – 0.150"	2,4
42.5	9614692705	7-207-MD	Nozzle – 0.165"	2,4
42.6	9614692706	7-207-MD	Nozzle – 0.187"	2,4
42.7	9614692707	7-207-MD	Nozzle – 0.200"	2
43	9614692801	7-208	Nozzle Housing Plug	2

8 Parts List and Service Kits

Pos.	AL No.	Gamajet No.	Description	No.
44	9614693001	7-212-FT	Output Shaft Extension	1
45	9614693101	7-217	Tee Housing Bevel Gear	1
46	9614693201	7-218	Nozzle Housing Bevel Gear	1
47	9614693301	7-219	Snap Ring	1
48	9614693701	7-233	Nozzle Housing Lower Bearing	1
49	9614693801	7-233-MD	Nozzle Housing Upper Bearing	1
50	9614694001	7-244-FT	Flow-Thru A2 Stem	1
51	9614694601	7-249	Button Head Screw	4
52	9614694701	7-250	Dowel Pin	1
53	9614635401	7-431-L	Tee Housing Lower Bearing	1
54	9614635501	7-431-U	Tee Housing Upper Bearing	1
55	9614636001	7-440	Tee Housing Bevel Gear Pin	1
56.1	9614637001	7-461-E	Tee Housing O-ring – EPDM	1
56.2	9614637101	7-461-K	Tee Housing O-ring – Kalrez	1
56.3	9614637201	7-461-V	Tee Housing O-ring – Viton	1
57	9614685501	7-740	Cap Screw	4
59	9614678701	8-549	Stream Straightener	2,4
60	9614617101	9-140	Collar Set Screw	1
61.1	9614662002	642-3	Gear Box O-ring - Viton	1
61.2	9614662003	642-3E	Gear Box O-ring – EPDM	1
61.3	9614662004	642-3Z	Gear Box O-ring – Kalrez	1
62	9614687201	758	Nozzle Housing Bevel Gear Pin	1
63	9614611101	E-866	Dowel Pin	4
64	9614694801	7-251	2" Adjustable Tank Connection	1

8 Parts List and Service Kits

8.9 Minor Service Kit

Article no: 9614695601 7NJFTEKIT ALFA LAVAL GJ A2 KIT - EPDM				
Pos. no.	Part No.	Gamajet Part No.	Description	No.
14	9614623501	6127	PLANETARY GEARHEAD BUSHING	12 pcs.
22	9614625501	61423A	PL OUTPUT SHAFT UPR BSG-3A	1 pcs.
26.1	9614626901	6153E	COLLAR SMALL O-RING EPDM	1 pcs.
27.1	9614627001	6154E	COLLAR LARGE O-RING - EPDM	1 pcs.
31	9614628701	6175	GEARHEAD O-RING - EPDM	1 pcs.
32.1	9614629401	6186E	GJ A6 LOWER BODY GASKET-EPDM	3 pcs.
33.1	9614629501	6187E	GJ A6 LARGE STEM GASKET-EPDM	1 pcs.
34.1	9614629701	6189E	GJ A6 ROTOR GASKET-EPDM	1 pcs.
53	9614635401	7431L	LOWER TEE HOUSING LAB SEAL	1 pcs.
54	9614635501	7431U	UPPER TEE HOUSING LAB SEAL	1 pcs.
48	9614693701	7233	ALPHA FP NOZZLE HSG BEARING	1 pcs.
49	9614693801	7233MD	NANOJET NOZZLE HSG BEARING	1 pcs.
56.1	9614637001	7461	STEM CAP O-RING EPDM	1 pcs.
61.2	9614662003	422170	642-3E GEARBOX STEM O-RING - E	3 pcs.

Article no: 9614695401 7NJFTK ALFA LAVAL GJ A2 KIT - KALREZ				
Pos. no.	Part No.	Gamajet Part No.	Description	No.
14	9614623501	6127	PLANETARY GEARHEAD BUSHING	12 pcs.
22	9614625501	61423A	PL OUTPUT SHAFT UPR BSG-3A	1 pcs.
26.3	9614626903	6153Z	COLLAR SMALL O-RING ZALAK	1 pcs.
27.3	9614627003	6154Z	COLLAR LARGE O-RING - ZALAK	1 pcs.
31	9614661403	381180	638-Z HOUSING O-RING UPPERII	1 pcs.
32.2	9614629402	6186K	GJ A6 LOWER BODY GASKET-KALREZ	3 pcs.
33.2	9614629502	6187K	GJ A6 LARGE STEM GASKET-KALREZ	1 pcs.
34.2	9614629702	6189K	GJ A6 ROTOR GASKET-KALREZ	1 pcs.
53	9614635401	7431L	LOWER TEE HOUSING LAB SEAL	1 pcs.
54	9614635501	7431U	UPPER TEE HOUSING LAB SEAL	1 pcs.
48	9614693701	7233	ALPHA FP NOZZLE HSG BEARING	1 pcs.
49	9614693801	7233MD	NANOJET NOZZLE HSG BEARING	1 pcs.
56.2	9614637101	7461K	STEM CAP O-RING - KALREZ	1 pcs.
61.3	9614662004	422180	642-3Z GEARBOX STEM O-RING - K	3 pcs.

8.10 Major Service Kit

Article no: 9614695701 7NJFTEMAJKIT ALFA LAVAL GJ A2 MAJOR KIT - EPDM				
Pos. no.	Part No.	Gamajet Part No.	Description	No.
14	9614623501	6127	PLANETARY GEARHEAD BUSHING	12 pcs.
22	9614625501	61423A	PL OUTPUT SHAFT UPR BSG-3A	1 pcs.
26.1	9614626901	6153E	COLLAR SMALL O-RING EPDM	1 pcs.
27.1	9614627001	6154E	COLLAR LARGE O-RING - EPDM	1 pcs.
31	9614628701	6175	GEARHEAD O-RING - EPDM	1 pcs.
32.1	9614629401	6186E	GJ A6 LOWER BODY GASKET-EPDM	3 pcs.
33.1	9614629501	6187E	GJ A6 LARGE STEM GASKET-EPDM	1 pcs.
34.1	9614629701	6189E	GJ A6 ROTOR GASKET-EPDM	1 pcs.
53	9614635401	7431L	LOWER TEE HOUSING LAB SEAL	1 pcs.
54	9614635501	7431U	UPPER TEE HOUSING LAB SEAL	1 pcs.
48	9614693701	7233	ALPHA FP NOZZLE HSG BEARING	1 pcs.
49	9614693801	7233MD	NANOJET NOZZLE HSG BEARING	1 pcs.
56.1	9614637001	7461	STEM CAP O-RING EPDM	1 pcs.
61.2	9614662003	422170	642-3E GEARBOX STEM O-RING - E	3 pcs.
9	9614622901	6122AS	INPUT PINION ASSEMBLY	1 pcs.
13	9614623401	6126	PLANETARY GEARHEAD LG WASHER	3 pcs.
15	9614623701	6128	PLANETARY GEAR	12 pcs.
16	9614623801	6129	PLANETARY GEAR WASHER	12 pcs.
17	9614623901	6130	PLANETARY GEAR IDLER SHAFT	12 pcs.
18	9614624901	6137	PLANETARY GEAR CARRIER	1 pcs.
19	9614625001	6138	PLANETARY GEAR CARRIER PINION	1 pcs.
20	9614625101	6140	PLANETARY OUTPUT SHAFT WASHER	1 pcs.
28	9614628101	6168	PLANETARY HOUSING SCREW	4 pcs.
29	9614628201	6170	PLANETARY OUTPUT SHAFT WASHER	1 pcs.
21	9614625301	6141FT	NANOJET FLOW-THRU OUTPUTSHAFT	1 pcs.

8 Parts List and Service Kits

Article no: 9614695501 7NJFTKMAJKIT ALFA LAVAL GJ A2 MAJOR KIT - KALREZ				
Pos. no.	Part No.	Gamajet Part No.	Description	No.
14	9614623501	6127	PLANETARY GEARHEAD BUSHING	12 pcs.
22	9614625501	61423A	PL OUTPUT SHAFT UPR BSG-3A	1 pcs.
26.3	9614626903	6153Z	COLLAR SMALL O-RING ZALAK	1 pcs.
27.3	9614627003	6154Z	COLLAR LARGE O-RING - ZALAK	1 pcs.
31	9614661403	381180	638-Z HOUSING O-RING UPPERII	1 pcs.
32.2	9614629402	6186K	GJ A6 LOWER BODY GASKET-KALREZ	3 pcs.
33.2	9614629502	6187K	GJ A6 LARGE STEM GASKET-KALREZ	1 pcs.
34.2	9614629702	6189K	GJ A6 ROTOR GASKET-KALREZ	1 pcs.
53	9614635401	7431L	LOWER TEE HOUSING LAB SEAL	1 pcs.
54	9614635501	7431U	UPPER TEE HOUSING LAB SEAL	1 pcs.
48	9614693701	7233	ALPHA FP NOZZLE HSG BEARING	1 pcs.
49	9614693801	7233MD	NANOJET NOZZLE HSG BEARING	1 pcs.
56.2	9614637101	7461K	STEM CAP O-RING - KALREZ	1 pcs.
61.3	9614662004	422180	642-3Z GEARBOX STEM O-RING - K	3 pcs.
9	9614622901	6122AS	INPUT PINION ASSEMBLY	1 pcs.
13	9614623401	6126	PLANETARY GEARHEAD LG WASHER	3 pcs.
15	9614623701	6128	PLANETARY GEAR	12 pcs.
16	9614623801	6129	PLANETARY GEAR WASHER	12 pcs.
17	9614623901	6130	PLANETARY GEAR IDLER SHAFT	12 pcs.
18	9614624901	6137	PLANETARY GEAR CARRIER	1 pcs.
19	9614625001	6138	PLANETARY GEAR CARRIER PINION	1 pcs.
20	9614625101	6140	PLANETARY OUTPUT SHAFT WASHER	1 pcs.
28	9614628101	6168	PLANETARY HOUSING SCREW	4 pcs.
29	9614628201	6170	PLANETARY OUTPUT SHAFT WASHER	1 pcs.
21	9614625301	6141FT	NANOJET FLOW-THRU OUTPUTSHAFT	1 pcs.

How to contact Alfa Laval Tank Equipment:

For further information, please feel free to contact:

Alfa Laval Tank Equipment

604 Jeffers Circle, Exton, PA 19341 USA

Tel switchboard: +01 610 408 9940 – Fax switchboard: +01 610 408 9945

www.gamajet.com, www.alfalaval.com, customer service: exton@alfalaval.com

contact details for all countries are continually updated on our websites.

© Alfa Laval Corporate AB

This document and its contents is owned by Alfa Laval Corporate AB and protected by laws governing intellectual property and thereto related rights. It is the responsibility of the user of this document to comply with all applicable intellectual property laws. Without limiting any rights related to this document, no part of this document may be copied, reproduced or transmitted in any form or by any means (electronic, mechanical, photocopying, recording, or otherwise), or for any purpose, without the expressed permission of Alfa Laval Corporate AB. Alfa Laval Corporate AB will enforce its rights related to this document to the fullest extent of the law, including the seeking of criminal prosecution.