



Instruction Manual

Alfa Laval Rotacheck Sensor and Relay

Covering: Standard Instruments
Instruments delivered with ATEX Certification in accordance Directive 2014/34/EU
IM-TE91A663
First published: 2010

ESE01763-EN15 2022-10

Original manual

The information herein is correct at the time of issue but may be subject to change without prior notice

1. Declarations of Conformity	4
2. Introduction	6
3. Overview of article numbers	7
3.1. Rotacheck Sensor, Relay and Welding adapter	7
4. Function	8
4.1. Sensor, TE53E067 and TE52E057	8
4.2. Universal Relay, TE52E058	9
4.3. Universal Relay, TE52E059	9
5. Power supply and signal	10
6. Installation	11
6.1. Position of Sensor in tank with welding adapter	11
7. Precautions when installing in Explosive atmosphere, classified in zones	13
7.1. Special conditions for safe use	14
7.2. Wiring	15
8. Rotation Verification	16
9. General information	18
9.1. ATEX Certificate of Conformity	18
9.2. Product repair	18
9.3. How to contact Alfa Laval Kolding A/S	18

1 Declarations of Conformity

EU Declaration of Conformity

The Designated Company

Alfa Laval Kolding A/S, Albuen 31, DK-6000 Kolding, Denmark, +45 79 32 22 00

Company name, address and phone number

Hereby declare that

Instrument

Designation

Alfa Laval Rotacheck Sensor and Relay

Type

Serial number from M924480 0001 and subsequent serial numbers

is in conformity with the following directives with amendments:

- EMC Directive 2014/30/EU
 - RoHS Directive 2011/65/EU and amendments
 - ATEX Directive 2014/34/EU
- and the following harmonized standards are used:
DS/EN ISO/IEC 80079-34:2011, DS/EN 60079-0:2012, DS/EN 60079-11:2012

Relay

EC Type Examination Certificate number Baseefa14ATE0178

Marking:  II (1) G [Ex ia Ga] IIC
II (1) D [Ex ia Da] IIIC IP20

Sensor

EC Type Examination Certificate number Baseefa14ATE0179X

Marking:  II (1) G
II (1) D
Ex ia IIC T6 Ga (-20°C ≤ TA ≤ +40°C)
Ex ia IIC T4 Ga (-20°C ≤ TA ≤ +90°C)
Ex ia IIIC T85°C Da (-20°C ≤ TA ≤ +40°C)
Ex ia IIIC T135°C Da (-20°C ≤ TA ≤ +90°C) IP68

The QAN (Quality Assurance Notification) is carried out by SGS Fimko Oy, Särkiniementie 3, Helsinki 00211, Finland. Notified Body no. 0598.
EU Type Examination Certification is carried out by SGS Fimko Oy, Särkiniementie 3, Helsinki 00211, Finland. Notified Body no. 0598.

The person authorised to compile the technical file is the signer of this document.

Global Product Quality Manager

Title

Lars Kruse Andersen

Name

Kolding, Denmark

Place

2022-10-01

Date (YYYY-MM-DD)

Signature

This Declaration of Conformity replaces Declaration of Conformity dated 2019-04-01



1 Declarations of Conformity

UK Declaration of Conformity

The Designated Company

Alfa Laval Kolding A/S, Albuen 31, DK-6000 Kolding, Denmark, +45 79 32 22 00

Company name, address and phone number

Hereby declare that

Instrument

Designation

Alfa Laval Rotacheck Sensor and Relay

Type

Serial number from M924480 0001 and subsequent serial numbers

is in conformity with the following directives with amendments:

- The Electromagnetic Compatibility Regulations 2016
- The Restriction of the Use of Certain Hazardous Substances in Electrical and Electronic Equipment Regulations 2012
- The Equipment and Protective Systems Intended for use in Potentially Explosive Atmospheres Regulations 2016

and the following harmonized standards are used:

DS/EN ISO/IEC 80079-34:2011, DS/EN 60079-0:2012, DS/EN 60079-11:2012

Relay

EC Type Examination Certificate number Baseefa14ATE0178

Marking:  II (1) G [Ex ia Ga] IIC

II (1) D [Ex ia Da] IIIC IP20

Sensor

EC Type Examination Certificate number Baseefa14ATE0179X

Marking:  II (1) G

II (1) D

Ex ia IIC T6 Ga (-20°C ≤ TA ≤ +40°C)

Ex ia IIC T4 Ga (-20°C ≤ TA ≤ +90°C)

Ex ia IIIC T85°C Da (-20°C ≤ TA ≤ +40°C)

Ex ia IIIC T135°C Da (-20°C ≤ TA ≤ +90°C) IP68

The QAN (Quality Assurance Notification) is carried out by SGS Fimko Oy, Särkiniementie 3, Helsinki 00211, Finland. Notified Body no. 0598.

EU Type Examination Certification is carried out by SGS Fimko Oy, Särkiniementie 3, Helsinki 00211, Finland. Notified Body no. 0598.

Signed on behalf of: Alfa Laval Kolding A/S

Global Product Quality Manager

Title

Lars Kruse Andersen

Name

Kolding, Denmark

Place

2022-10-01

Date (YYYY-MM-DD)

Signature

DoC Revison_01_102022



2 Introduction

The Alfa Laval Sanitary Rotacheck System consisting of a Universal Relay and a Sensor designed for confirmation of correct functioning of the installed Jet Head tank cleaning machine and to verify that the entire internal tank surface is cleaned.

The system is protected for use in potentially explosive atmospheres according to relevant standards stated in the ATEX certificate and EC Declaration attached.

The English version of the instruction manual is the original manual. We make reservations in regard to possible mistranslations in language versions of the instruction manual. In case of doubt, the English version of the instruction manual applies.

NOTE!

The illustrations and specifications contained in this manual were effective at the date of printing. However, as continuous improvement is the policy of Alfa Laval Kolding A/S, we reserve the right to alter or modify any unit specification on any product without notice or any obligation.

3.1 Rotacheck Sensor, Relay and Welding adapter

Denomination	With ATEX	With ATEX and 3.1 certificate	With 3.1 certificate
Rotacheck/Sensor w. 2m cable	N/A	TE52E067-90	N/A
Rotacheck/Sensor w. 10m cable	N/A	TE52E067-91	N/A
Rotacheck/Sensor (3/4" tread) w. 2m cable	N/A	TE52E057-90	N/A
Rotacheck/Sensor (3/4" tread) w. 10m cable	N/A	TE52E057-91	N/A
Rotacheck/Relay (AC) Universal 24 – 115 - 230 V AC	TE52E058	N/A	N/A
Rotacheck/Relay (DC) Universal 12 - 36 V DC	TE52E059	N/A	N/A
Rotacheck/Relay (AC)+sensor Universal, w. 2m cable 24 – 115 - 230 V AC	N/A	TE52E070-90	N/A
Rotacheck/Relay (AC)+sensor Universal, w. 10m cable 24 – 115 - 230 V AC	N/A	TE52E070-91	N/A
Welding adapter for Rotacheck sensor TE52E067	N/A	N/A	TE52E068-90
Welding adapter for Rotacheck sensor TE52E057	N/A	N/A	TE52E052-90

4 Function

The RJH tank cleaning machine rotates on two axes during the course of the cleaning process, ensuring that the entire internal tank surface is flushed a predetermined number of times.

The water jet will hit the Rotacheck sensor membrane at uneven intervals. The impulse from the sensor membrane will trigger an electric output signal from the sensor. This is passed to the Rotacheck relay where it is converted to an "open collector" signal on terminals 28, 29 and 30, and a relay signal (switch contact) on terminals 23, 24 and 25 respectively.

4.1 Sensor, TE53E067 and TE52E057

Weight of unit without cable:	52E067 / 167 g ; 52E057 / 216 g
Weight of cable:	50 g/m
Connection, electrical:	2 or 10 meter cable, ø6 mm, 2x0.75 mm ² shielded
Pressure for sensor function:	min: 0.1 bar. max.: 2 bar
Overload pressure:	max.: 15 bar
Max. repetitions freq. for sensor function:	2 Hz
Duration of electrical output pulse:	min. 1.0 sec.
Area of diaphragm:	360 mm ²
Operating temp., sensor:	-20°C to +90°C
Max. media temperature on diaphragm when not operating:	+140°C
Material, sensor and diaphragm:	AISI 316L
Enclosure:	IP 68
Ex-category and Ex data:	See marking label

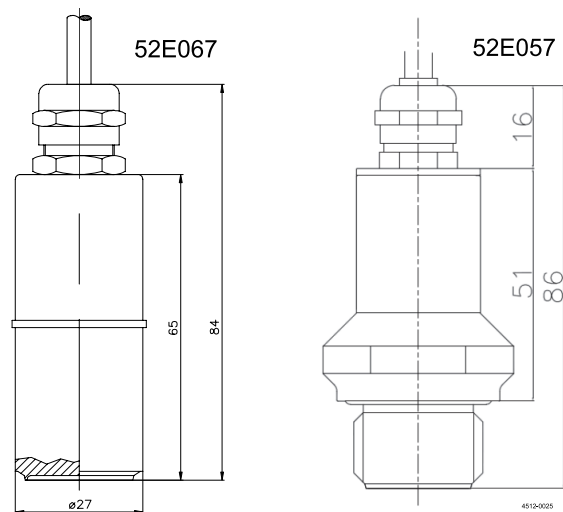

4.2 Universal Relay, TE52E058

Mounting:	By clipping onto 35 mm standard rail to DIN/EN50022 or by screw fixing.
Weight:	550 g
Supply voltage, Terminals 16-17-18-19:	24-115-230V AC, 50-60 Hz
Power consumption:	<4VA
Output voltage for sensor, nominal, Terminal 1-2:	10 V
Output current for sensor, nominal:	5mA
Output f. external load, Terminal 23-24-25:	Relay switch, 250V, 2A AC
DC output: Terminal 29-30 (max. 50 mA):	24V DC
Open collector output, Terminal 28-29 (max. 50mA):	<50V DC
Operating temp., relay:	-20°C to +40°C
Enclosure:	IP 20
Ex-category and Ex data:	See marking label

4.3 Universal Relay, TE52E059

Mounting:	By clipping onto 35 mm standard rail to DIN/EN50022 or by screw fixing.
Weight:	550 g
Supply voltage, Terminals 16-19:	12 – 36V DC
Power consumption:	<4VA
Output voltage for sensor, nominal, Terminal 1-2:	10 V
Output current for sensor, nominal:	5mA
Output f. external load, Terminal 23-24-25:	Relay switch, 250V, 2A AC
DC output: Terminal 29-30 (max. 50 mA):	24V DC
Open collector output, Terminal 28-29 (max. 50mA):	<50V DC
Operating temp., relay:	-20°C to +40°C
Enclosure:	IP 20
Ex-category and Ex data:	See marking label

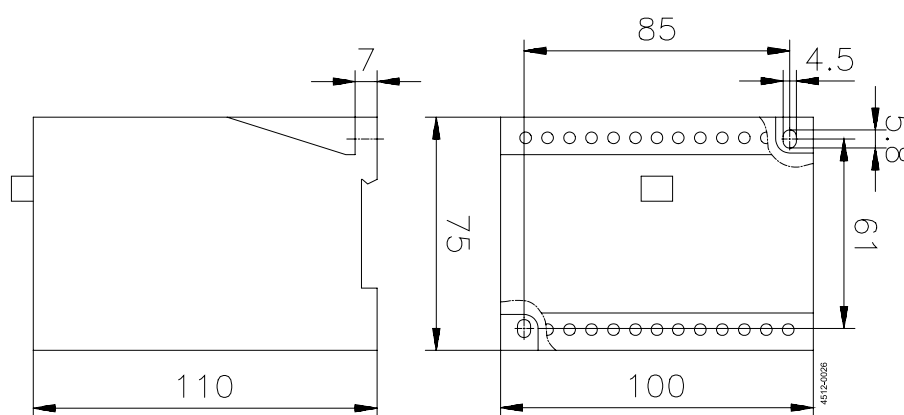

5 Power supply and signal

Power supply and signal The Universal Relay 52E058 can be supplied from AC mains 230 V (+/- 10%), 50-60 Hz, terminal 16 and 19 or alternatively 115 V terminal 16 and 18 or 24 V terminal 16 and 17.

The Universal Relay 52E059 can be supplied with 12 to 36 V DC at terminal 16 and 19.

The relays contains the necessary zener barriers needed to make the system intrinsically safe.

The built-in electronics constitutes the power supply for the Sensor supplying the required current and voltage. Power consumption from the mains is approx. 4 VA.

The Sensor has a built-in automatic zero-adjustment, which compensates for a standing pressure without giving a signal. This enables the system to operate in tanks under pressure.

The Sensor is a 2-wire open collector that cannot be supplied from a traditional power supply. The electrical output pulse is extended to 1 sec. for normal pressure loads. The cable is shielded in order to protect the system against disturbance from electro-magnetic noise.

Outputs from the Relay are:

1. a relay switch rated at max. 250V, 2A AC (terminal 23, 24 and 25)
2. a DC output facility supplying 24 V. Max load is 50 mA (terminal 29 and 30)
3. a DC signal of open collector type for PLC link-up. Max load is 50 mA and max. voltage is 50 V (terminal 28 and 29).

6.1 Position of Sensor in tank with welding adapter

In order to ensure correct signals, the sensor should be placed at the correct distance from the centre line of the down pipe according to the tank cleaning machine in question:

TJ40G	a =	91 mm
TJ20G	a =	75 mm
TZ-74	a =	78 mm
TZ-79	a =	98 mm
TZ-89	a =	50-90 mm *)

*) depending on size of mounting connection

Deviations from the above given positions may work, but will influence the signal sequence. It is not recommended to go closer to the centre line, as there is a risk of having no signal. If the Sensor is placed further away from the centre line, the number of times it is directly hit by a jet reduces, and if too far away, there is a risk that the sensor is not directly hit by the jets at all.

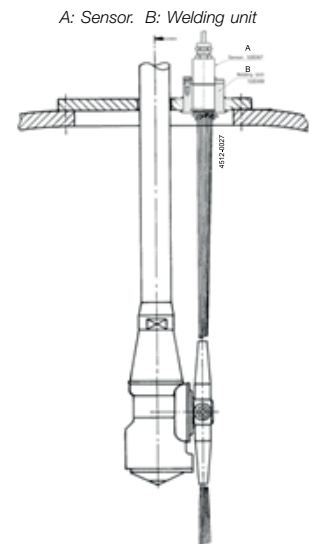

Installation of Rotacheck sensor 52E067

The Rotacheck sensor 52E067 can be mounted in the tank using welding adapter 52E068 or by using SanJet 20, 4" machine prepared for mounting of Rotacheck.

Bore hole $\varnothing 50 +0.3/-0.0$ mm, in top flange or tank.

Remove O-ring and push in adapter. TIG-weld on both sides adding the minimum amount of filler material and heat input in order to avoid deformation of the thread.

After welding and cleaning the weld, reinsert O-ring and mount Sensor as described above.

A: Sensor. B: Welding unit.
C: Max. 25. D: Hole.

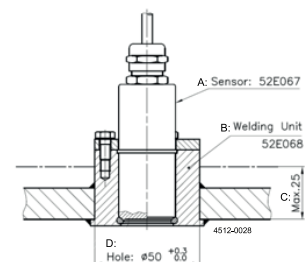

Installation of Rotacheck sensor 52E057

The Rotacheck sensor 52E057 can be mounted in the tank using welding adapter 52E052.

Bore hole $\varnothing 38 +0.3/-0.0$ mm, in top flange or tank.

Remove O-ring and push in adapter. TIG-weld on both sides adding the minimum amount of filler material and heat input in order to avoid deformation of the thread.

After welding and cleaning the weld, reinsert O-ring and mount Sensor as described above.

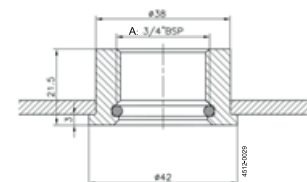

A: $\frac{3}{4}$ " BSP

6 Installation

Example of installation of Rotacheck system with sensor mounted in tank, relay installed in control room.

A: Ex zone 0. B: Ex zone 1. C: Ex zone 2. D: Cable length. E: PA. F: Safe area. G: 230 V Line

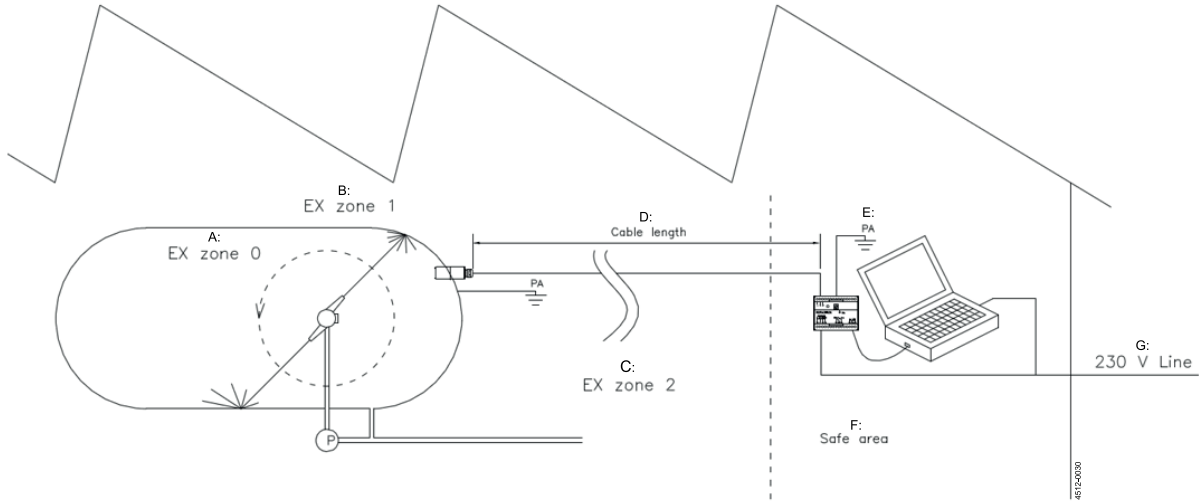

Connecting sensor to relay

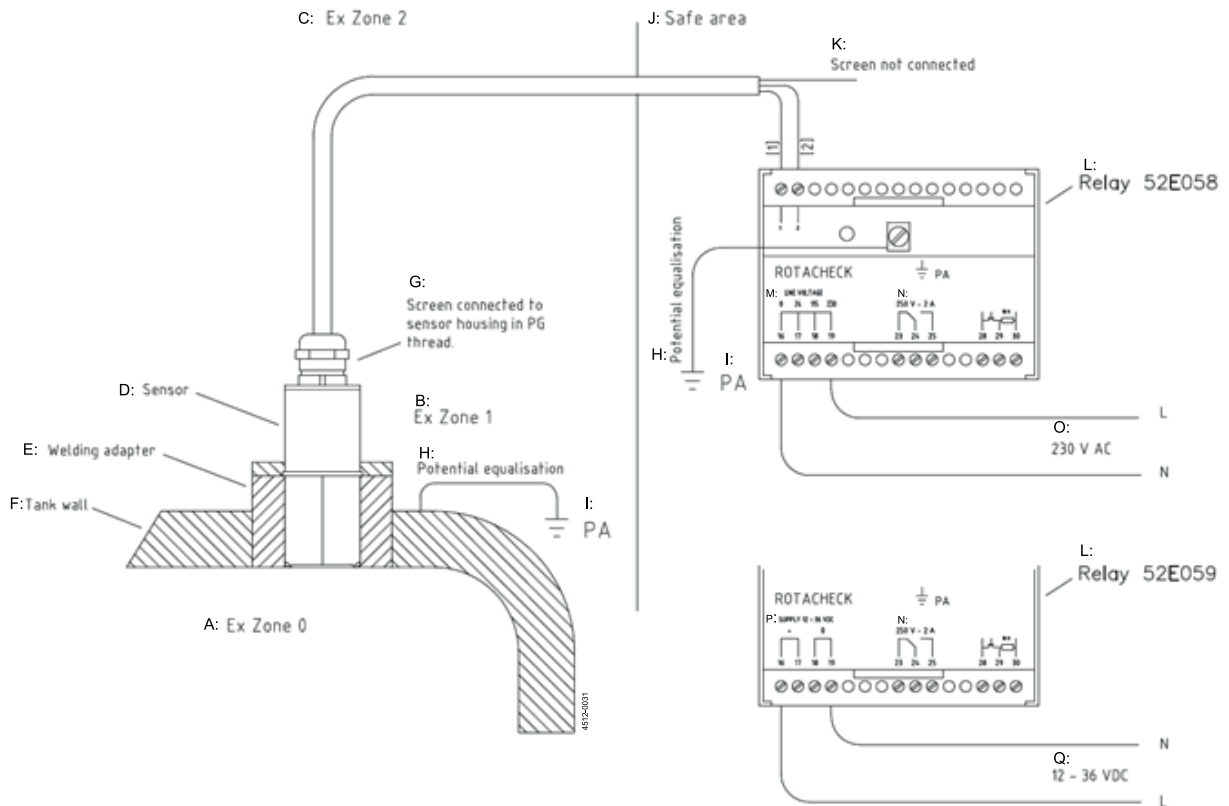

A: Ex zone 0. B: Ex zone 1. C: Ex zone 2. D: Sensor. E: Welding adapter. F: Tank wall. G: Screen connected to sensor housing in PG thread. H: Potential equalization. I: PA. J: Safe area. K: Screen not connected. L: Relay. M: Line voltage. N: 250 V - 2 A. O: 230 V AC. P: Supply 12 - 36 VDC. Q: 12 - 36 VDC.

7 Precautions when installing in Explosive atmosphere, classified in zones

The Rotacheck sensor must always be supplied through the Rotacheck relay, as the system's Ex-safety is based on the relay limiting the current and voltage to the levels acceptable within Ex zones.

The Rotacheck sensor 52E067 must be permanently mounted in the tank or SaniJet 20 machine, and always in the welded adapter TE52E068 or SaniJet 20 machine. The welding adapter can be supplied as an optional extra part.

The Rotacheck sensor 52E057 must be permanently mounted in the tank, and always in the welding adapter 52E052. The welding adapter can be supplied as an optional extra part.

The Rotacheck sensor can be mounted in tanks having Ex Zone 0 or Zone 20 when the requirements in this installation guide are met.

In an Ex environment, the sensor must be used within temperature range as specified on marking label.

The sensor is marked with the following specifications giving Ex safety:

ROTACHECK SENSOR 52E067

CE 0598 Ex II 1 G Baseefa14ATEX0179X
II 1 D

Ex ia IIC T6 Ga (-20°C ≤ Ta ≤ +40°C)
Ex ia IIC T4 Ga (-20°C ≤ Ta ≤ +90°C)
Ex ia IIIC T85 C Da (-20°C ≤ Ta ≤ +40°C)
Ex ia IIIC T135 C Da (-20°C ≤ Ta ≤ +90°C) IP68

Alfa Laval Kolding A/S
Albuen 31
DK 6000 Kolding - Denmark

Ui:10,6 V - Ii:15 mA - Ci:10 nF - Li:100 μH

ROTACHECK SENSOR 52E057

CE 0598 Ex II 1 G Baseefa14ATEX0179X
II 1 D

Ex ia IIC T6 Ga (-20°C ≤ Ta ≤ +40°C)
Ex ia IIC T4 Ga (-20°C ≤ Ta ≤ +90°C)
Ex ia IIIC T85°C Da (-20°C ≤ Ta ≤ +40°C)
Ex ia IIIC T135°C Da (-20°C ≤ Ta ≤ +90°C) IP68

Alfa Laval Kolding A/S
Albuen 31
DK 6000 Kolding - Denmark

Ui:10,6 V - Ii:15 mA - Ci:10 nF - Li:100 μH

The Rotacheck relay, which must be installed in safe area outside Ex Zone, is marked with the following specifications giving Ex safety:

ROTACHECK RELAY 52E058

CE 0598 Baseefa14ATEX0178

Ex II (1) G [Ex ia Ga] IIC
II (1) D [Ex ia Da] IIIC
IP 20

Alfa Laval Kolding A/S
Albuen 31
DK 6000 Kolding - Denmark

Uo:10,6 V - Io:15 mA - Co:2,3 μF - Lo:100 mH
Intrinsic safe circuit 1 - 2 - 3
Supply circuit: 16 - 17 - 18 - 19 24 - 115 - 230 V Um: 250 V
Output circuit: Relay: 23 - 23 - 25 - Open collector: 28 - 29 - 30

ROTACHECK RELAY 52E059

CE 0598 Baseefa14ATEX0178

Ex II (1) G [Ex ia Ga] IIC
II (1) D [Ex ia Da] IIIC
IP 20

Alfa Laval Kolding A/S
Albuen 31
DK 6000 Kolding - Denmark

Uo:10,6 V - Io:15 mA - Co:2,3 μF - Lo:100 mH
Intrinsic safe circuit 1 - 2 - 3
Supply circuit: 16 - 19 12 - 36 V d.c. Um: 250 V a.c.
Output circuit: Relay: 23 - 23 - 25 - Open collector: 28 - 29 - 30

Batch code and production date can be seen on the label for sensor and relay.

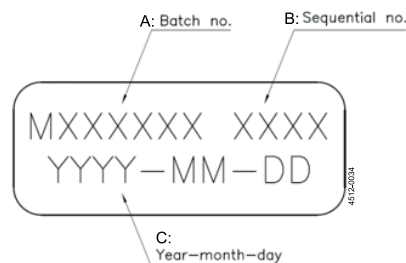

A: Batch no. B: Sequential no. C: Year-month-day

7 Precautions when installing in Explosive atmosphere, classified in zones

Principle diagram of electrical circuit for intrinsic safety:

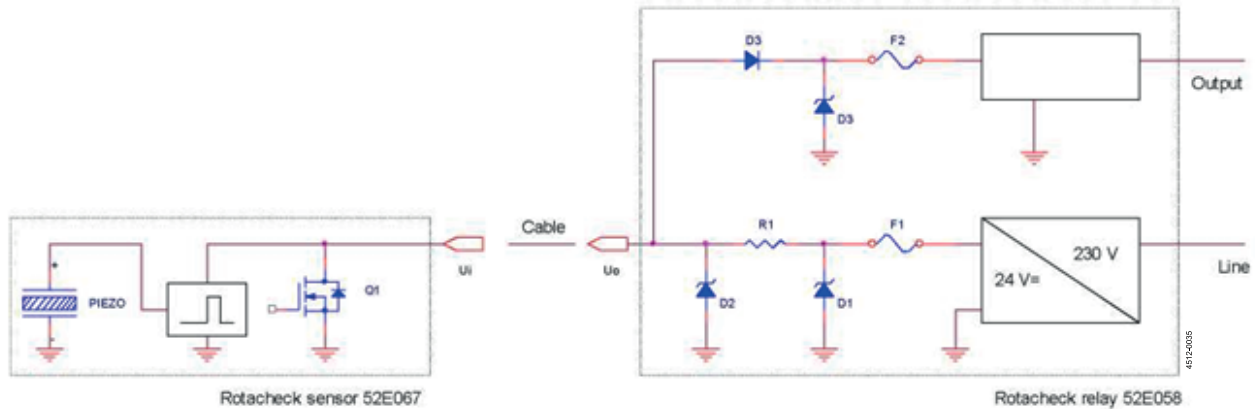

A: Rotacheck sensor 52E067. B: Rotacheck relay 52E058. C: Piezo. D: Cable. E: Output. F: Line. G: 24 V=. H: 230V. .

Technical specification for the Rotacheck cable giving Ex safety:

L_c : 1 μ /H

L_c : 200pF/m

L_i : 100 μ H

L_i : 10nF

7.1 Special conditions for safe use

Only permanent wired cables may be entered. The user shall provide the required strain relief.

Maximum length of the cable linking the relay and sensor shall be calculated and installed according to EN60079-14 by personal fulfill the demand in Annex A.

Example for calculation of the cable length:

The electrical parameters (C_c and L_c) or (C_c and L_c/R_c) for cable used shall be determined or the follow data can be used:

C_c : 200 pF/m and L_c : 1 μ H/m (with or without screen).

L_i less than 1% of L_o and C_i less than 1 % of C_o , therefore the following apply:

$$C_c = (C_o - C_i) / C_c/m$$

$$C_c = (2300nF - 10nF) / 0,2nF/m = 11.450 \text{ m}$$

$$L_c = (L_o - L_i) / L_c/m$$

$$L_c = (100 \text{ mH} - 0,1mH) / 0,001mH/m = 99.900 \text{ m}$$

It is not recommended to have a total cable length above 200 meter.

The screen is connected to the sensor and shall therefore be floating at the relay.

7 Precautions when installing in Explosive atmosphere, classified in zones

7.2 Wiring

Sensor and Relay box must always be fitted and wired according to the national regulations.

The system can be mounted with up to 200 m cable between Sensor and Relay. When extending the cable, make sure that the shield is properly connected.

Power supply to relay:

The relay 52E058 can be supplied with 24 or 115 or 230 V AC.

The relay 52E059 can be supplied with 12 - 36 V DC.

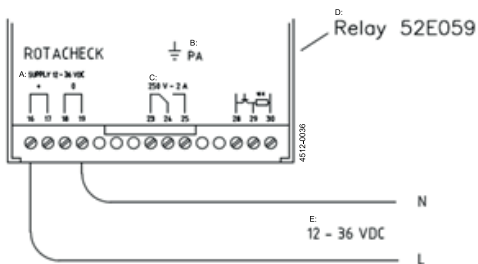

A: Supply 12 – 36 B: PA. C: 250 V- 2 A. D: Relay

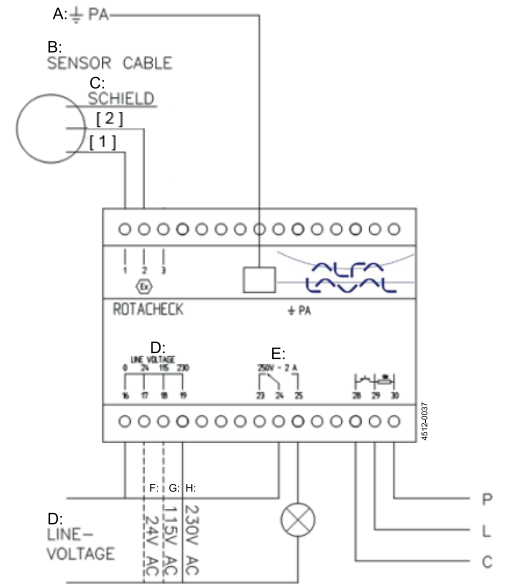

A: PA. B: Sensor cable. C: Shield. D: Line voltage.
E: 250 V – 2. F: 24V AC. G: 115V AC. H: 230V AC

Example 1:

Relay coupled to typical PLC with “pull-up” resistance

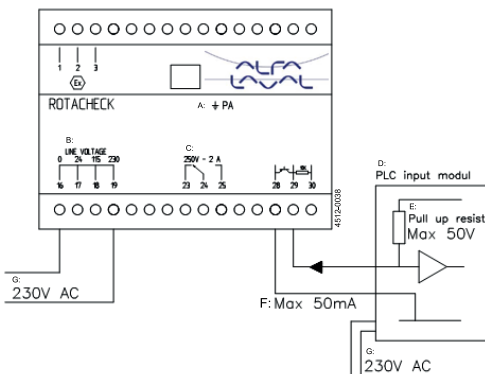

A: PA. B: Line voltage. C: 250V - 2A. D: PLC input module. E: Pull up resistor max. 50 V. F: Max. 50 mA. G: 230V AC.

Example 2:

Relay can be used to drive various loads, for example an external relay, a lamp, a light diode with resistance or a buzzer:

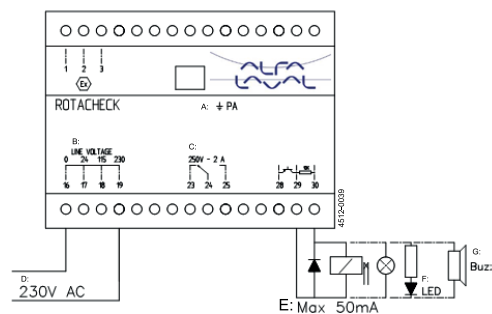

A: PA. B: Line voltage. C: 250V - 2 A. D: 230V AC. E: Max. 50 mA. F: LED. G: Buzzer

8 Rotation Verification

When the Tank Cleaning Machine and the Rotacheck system are installed, it is recommended to run a functional test of min. 20 min. to observe the max./min. number of hits per time window/slot of 3 minutes. This is the basis of the alarm limits to be entered into the user's control system.

Test results are depending on several factors: Inlet pressure, down pipe length, number of nozzles and nozzle size

The following table shows results from a similar test.

Test no.	1
SaniJet 20 4xØ4,2 700mm	
Date	42630
Start time	0,639583
Stop time	0,654167
Test time span in minutes	0,014583
Inlet pressure (Bar(g))	5
Max. Hits per 1min. slot	8
Min. Hits per 1min. slot	4
Max. Hits per 2min. slot	14
Min. Hits per 2min. slot	11
Max. Hits per 3min. slot	21
Min. Hits per 3min. slot	17

For the same types of machines, test results may vary due to tolerances of the machines.

In order to select useful alarm limits it is recommended to set the Min. alarm limit approx 10% lower than the test result, and the Max. alarm limit approx 20% higher than the test result.

Example of the alarm limits can be:

- Max. alarm limit = $21 + 20\% (4.2 - 4) = 25$
- Min. alarm limit = $17 - 10\% (1.7 - 2) = 15$

Recommended: 3 min. time slot

Alfa Laval recommends using a time slot of 3 minutes to determine the number of hits used for alarm determination.

Every second the sensor relay sends a data log signal to the PLC and every second the 3 minutes time slot should move a second. In this way we will have a moving time slot that gives us a real time hit rate which is recommended by Alfa Laval.

	Dato/Tid	mA	Numbers of signals	Hits	Hits per 3min. Slot
1					
2					
3					
4	17-09-2009 15:21:00	6,9	FALSE	0	18
5	17-09-2009 15:21:01	6,9	FALSE	0	18
6	17-09-2009 15:21:02	6,9	FALSE	0	18
7	17-09-2009 15:21:03	6,9	FALSE	0	18
8	17-09-2009 15:21:04	6,9	FALSE	0	18
9	17-09-2009 15:21:05	6,9	FALSE	0	18
10	17-09-2009 15:21:06	6,9	FALSE	0	18
11	17-09-2009 15:21:07	6,9	FALSE	0	18
12	17-09-2009 15:21:08	6,9	FALSE	0	18
13	17-09-2009 15:21:09	6,9	FALSE	0	19
14	17-09-2009 15:21:10	9,5	1	0	19
15	17-09-2009 15:21:11	9,5	1	1	19
16	17-09-2009 15:21:12	6,9	FALSE	0	18
17	17-09-2009 15:21:13	6,9	FALSE	0	18
179	17-09-2009 15:23:55	6,9	FALSE	0	19
180	17-09-2009 15:23:56	6,9	FALSE	0	19
181	17-09-2009 15:23:57	6,9	FALSE	0	19
182	17-09-2009 15:23:58	8,2	1	0	19
183	17-09-2009 15:23:59	9,5	1	1	19
184	17-09-2009 15:24:00	6,9	FALSE	0	18
185	17-09-2009 15:24:01	6,9	FALSE	0	19
186	17-09-2009 15:24:02	6,9	FALSE	0	19
187	17-09-2009 15:24:03	6,9	FALSE	0	19
188	17-09-2009 15:24:04	6,9	FALSE	0	19
189	17-09-2009 15:24:05	6,9	FALSE	0	19

Hit sum-up of 3 min. interval

If it is not possible to provide the PC software with the recommended 3 min. time slot it is possible to use a hit sum-up every 3 minutes. The sum-up should be of a 3 minutes period.

	Dato/Tid	mA	Numbers of signals	Hits	Hits per 3min. Interval
1					
2					
3					
4	17-09-2009 15:21:00	6,9	FALSE	0	
5	17-09-2009 15:21:01	6,9	FALSE	0	
6	17-09-2009 15:21:02	6,9	FALSE	0	
7	17-09-2009 15:21:03	6,9	FALSE	0	
8	17-09-2009 15:21:04	6,9	FALSE	0	
9	17-09-2009 15:21:05	6,9	FALSE	0	
10	17-09-2009 15:21:06	6,9	FALSE	0	
11	17-09-2009 15:21:07	6,9	FALSE	0	
12	17-09-2009 15:21:08	6,9	FALSE	0	
13	17-09-2009 15:21:09	6,9	FALSE	0	
14	17-09-2009 15:21:10	9,5	1	0	
15	17-09-2009 15:21:11	9,5	1	1	
16	17-09-2009 15:21:12	6,9	FALSE	0	
178	17-09-2009 15:23:54	6,9	FALSE	0	
179	17-09-2009 15:23:55	6,9	FALSE	0	
180	17-09-2009 15:23:56	6,9	FALSE	0	
181	17-09-2009 15:23:57	6,9	FALSE	0	
182	17-09-2009 15:23:58	8,2	1	0	
183	17-09-2009 15:23:59	9,5	1	1	18
184	17-09-2009 15:24:00	6,9	FALSE	0	
185	17-09-2009 15:24:01	6,9	FALSE	0	
186	17-09-2009 15:24:02	6,9	FALSE	0	
353	17-09-2009 15:26:49	6,9	FALSE	0	
354	17-09-2009 15:26:50	9,5	1	0	
355	17-09-2009 15:26:51	9,5	1	1	
356	17-09-2009 15:26:52	6,9	FALSE	0	
357	17-09-2009 15:26:53	6,9	FALSE	0	
358	17-09-2009 15:26:54	6,9	FALSE	0	
359	17-09-2009 15:26:55	6,9	FALSE	0	
360	17-09-2009 15:26:56	6,9	FALSE	0	
361	17-09-2009 15:26:57	6,9	FALSE	0	
362	17-09-2009 15:26:58	6,9	FALSE	0	
363	17-09-2009 15:26:59	6,9	FALSE	0	
364	17-09-2009 15:27:00	9,5	1	0	
365	17-09-2009 15:27:01	9,5	1	1	
366	17-09-2009 15:27:02	6,9	FALSE	0	

9 General information

9.1 ATEX Certificate of Conformity

EC – TYPE EXAMINATION CERTIFICATE available on Alfa Laval Anytime: <http://www.alfalaval.com/service-and-support/alfa-laval-anytime>

9.2 Product repair

Product repair requires return to Alfa Laval Kolding A/S.

9.3 How to contact Alfa Laval Kolding A/S

For further information please feel free to contact:

Alfa Laval Kolding A/S

31, Albuen - DK 6000 Kolding - Denmark

Registration number: 30938011

Tel switchboard: +45 79 32 22 00 - Fax switchboard: +45 79 32 25 80

www.toftejorg.com, www.alfalaval.dk - info.dk@alfalaval.com

Contact details for all countries are continually updated on our websites

How to contact Alfa Laval

Contact details for all countries are continually updated on our website.

Please visit www.alfalaval.com to access the information directly.

© Alfa Laval Corporate AB

This document and its contents is owned by Alfa Laval Corporate AB and protected by laws governing intellectual property and thereto related rights. It is the responsibility of the user of this document to comply with all applicable intellectual property laws. Without limiting any rights related to this document, no part of this document may be copied, reproduced or transmitted in any form or by any means (electronic, mechanical, photocopying, recording, or otherwise), or for any purpose, without the expressed permission of Alfa Laval Corporate AB. Alfa Laval Corporate AB will enforce its rights related to this document to the fullest extent of the law, including the seeking of criminal prosecution.